

DATA SHEET

MODULETEK: SFP-OC12-LR2-C10

OC-12 LR-2 SFP(Small Form Pluggable) Transceiver with Digital Diagnostics

SFP-OC12-LR2-C10 Overview

ModuleTek's SFP-OC12-LR2-C10 optical transceivers are designed to comply with SONET and SDH standards at OC-12 LR-2/STM L-4.2. The product implements digital diagnostics via a 2-wire serial bus, compliant with the Small Form Factor Pluggable Multi-Source Agreement (MSA).

Product Features

- Up to 622Mb/s bi-directional data links
- Hot-Pluggable
- Duplex LC connector
- Up to 80km on 9/125µm SMF
- Uncooled 1550nm DFB laser transmitter
- Single power supply 3.3V
- Built-in digital diagnostic functions
- Low power dissipation <700mW
- RoHS Compliant
- Operating case temperature range: 0°C to 70°C

Applications

- SONET OC-12 LR-2/SDH STM L-4.2

Ordering Information

Part Number	Description	Color on Clasp
SFP-OC12-LR2-C10	OC-12 LR-2 SFP Transceiver, LC Connectors, Single Mode Fiber 80km	White
For More Information: ModuleTek Limited Web: www.moduletek.com Email: sales@moduletek.com		

General Specifications

Parameter	Symbol	Min	Typ	Max	Unit	Remarks
Data Rate	DR		622		Mb/s	1
Bit Error Rate	BER			10^{-12}		
Operating Temperature	T _C	0		70	°C	2
Storage Temperature	T _{STO}	-40		85	°C	3
Supply Current	I _{CC}			300	mA	4
Input Voltage	V _{CC}	3.14		3.46	V	
Maximum Voltage	V _{MAX}	-0.5		4.5	V	4

Notes:

1. Compliant with SONET and SDH at the OC-12 LR-2/STM L-4.2.
2. Case temperature
3. Ambient temperature
4. For electrical power interface

Optical – Characteristics – Transmitter

$V_{CC}=3.14V$ to $3.46V$, $T_C=0^{\circ}C$ to $70^{\circ}C$

Parameter	Symbol	Min	Typ	Max	Unit	Remarks
Output Optical Power	P_{TX}	-3		2	dBm	1
Optical Center Wavelength	λ_C	1480		1580	nm	
Extinction Ratio	ER	10			dB	
Spectral Width(-20dB)	$\Delta\lambda$			1	nm	
Optical Rise/Fall Time(20%-80%)	t_r/t_f			300	ps	
Relative Intensity Noise	RIN			-120	dB/Hz	
Generated Jitter(peak to peak)	TJ_{p-p}			0.07	UI	
Generated Jitter(rms)	TJ_{rms}			0.007	UI	
Mask Margin			20%			

Notes:

1.Average Launch Power

Optical – Characteristics – Receiver

$V_{CC}=3.14V$ to $3.46V$, $T_C=0^{\circ}C$ to $70^{\circ}C$

Parameter	Symbol	Min	Typ	Max	Unit	Remarks
Average Receiver Sensitivity	RX_SEN	-28		-8	dBm	1
Receiver Overload	P_{OL}	0			dBm	
Optical Center Wavelength	λ_C	1260		1600	nm	
LOS Assert	LOS_A	-45			dBm	
LOS De-Assert	LOS_D			-28	dBm	
LOS Hysteresis	LOS_H	0.5			dB	

Notes:

1.Measured with a PRBS $2^{23}-1$ test pattern.

Electrical – Characteristics – Transmitter

$V_{CC}=3.14V$ to $3.46V$, $T_C=0^{\circ}C$ to $70^{\circ}C$

Parameter	Symbol	Min	Typ	Max	Unit	Remarks
Input differential impedance	R_{IN}		100		Ω	1
Single ended data input swing	V_{IN_PP}	250		1200	mV	
Transmit disable voltage	V_D	$V_{CC}-1.3$		V_{CC}	V	
Transmit enable voltage	V_{EN}	V_{EE}		$V_{EE}+0.8$	V	2

Notes:

- 1.AC coupled
- 2.Or open circuit

Electrical – Characteristics – Receiver

$V_{CC}=3.14V$ to $3.46V$, $T_C=0^{\circ}C$ to $70^{\circ}C$

Parameter	Symbol	Min	Typ	Max	Unit	Remarks
Single ended data output swing	V_{OUT_PP}	300	400	800	mV	
Data Rise/Fall time (20%-80%)	t_r/t_f		150	300	ps	
LOS asserted	V_{LOS_A}	$V_{CC}-0.5$		V_{CC_HOST}	V	
LOS de-asserted	V_{LOS_D}	V_{EE}		$V_{EE}+0.5$	V	

Digital Diagnostic Functions

SFP-OC12-LR2-C10 supports the 2-wire serial communication protocol as defined in SFP MSA. Digital diagnostic information is accessible over the 2-wire interface at the address 0xA2. Digital diagnostics for SFP-OC12-LR2-C10 are internally calibrated by default. The internal micro control unit accesses the device operating parameters in real time, Such as transceiver temperature, laser bias current, transmitted optical power, received optical power and transceiver supply voltage. The module implements the alarm function of the SFP MSA, alerts the user when a particular operating parameter exceeds the factory-set normal range.

Block-Diagram-of-Transceiver

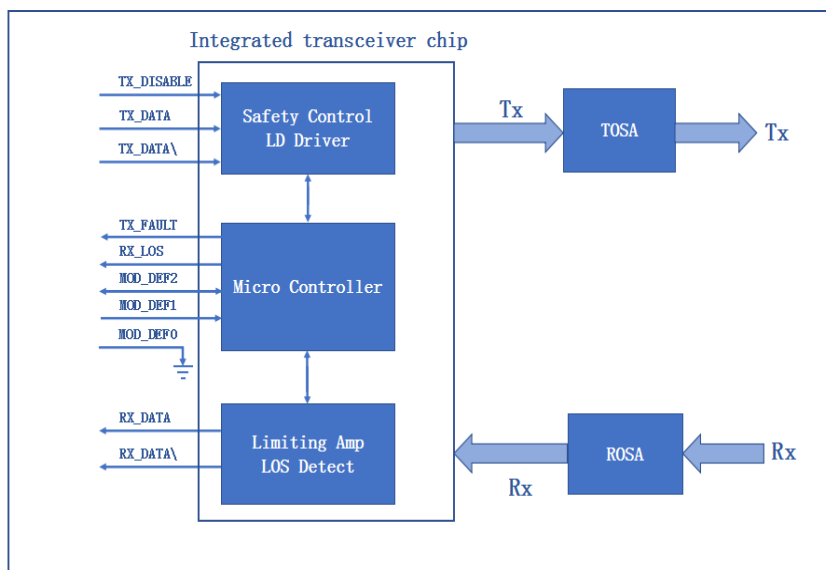

Functions Description

The transmitter is mainly composed of a laser driver part of the intelligent transceiver chip and a TOSA (light-emitting component), the TOSA includes a 1550nm DFB laser and a backlight photodetection chip. When the module is working, the input signal is connected to the intelligent transceiver chip, at this time, the laser driver of the intelligent transceiver chip supplies the bias current and the modulation current to the laser. The intelligent transceiver chip simultaneously uses an automatic optical power control (APC) feedback loop to maintain a constant average optical power of the laser output. The purpose is to eliminate the change of the output optical signal due to temperature changes and aging of the light source device. When the transmitter enable pin (TX_Disable) is high (TTL logic "1"), the laser output is turned off. When TX_Disable is low (TTL logic "0"), the laser will turn on within 1ms. When the transmitter fault signal (TX_Fault) is reported as high, indicates a transmitter failure caused by the transmitter's bias current or transmitted optical power or laser tube temperature exceeding a preset alarm threshold. Low indicates normal operation.

The receiver is mainly composed of a limiting amplifier part of the intelligent transceiver chip and a ROSA (light-receiving component), the ROSA includes a PIN photodetector and a transimpedance amplifier chip. When the ROSA detects the incident light signal, it will be converted into a photo-generated current by the PIN photodetector. The photo-generated current is converted into an electrical signal after passing through the transimpedance amplifier. The electrical signal is further amplified by the limiting amplifier of the intelligent transceiver chip, then outputs a fixed-amplitude electrical signal to the host. When the amplitude of the electrical signal received from the incident light conversion of the opposite optical transceiver module is lower than the set threshold, the module reports that the received signal is lost, the RX_LOS pin is high (logic "1"), which can be used to diagnose whether the physical signal is normal. The signal is operated in TTL level. The microprocessor inside the module monitors the module's operating voltage, temperature, transmitted optical power, received optical power, and laser bias current value in real time. The host acquires this information over a 2-wire serial bus.

Dimensions

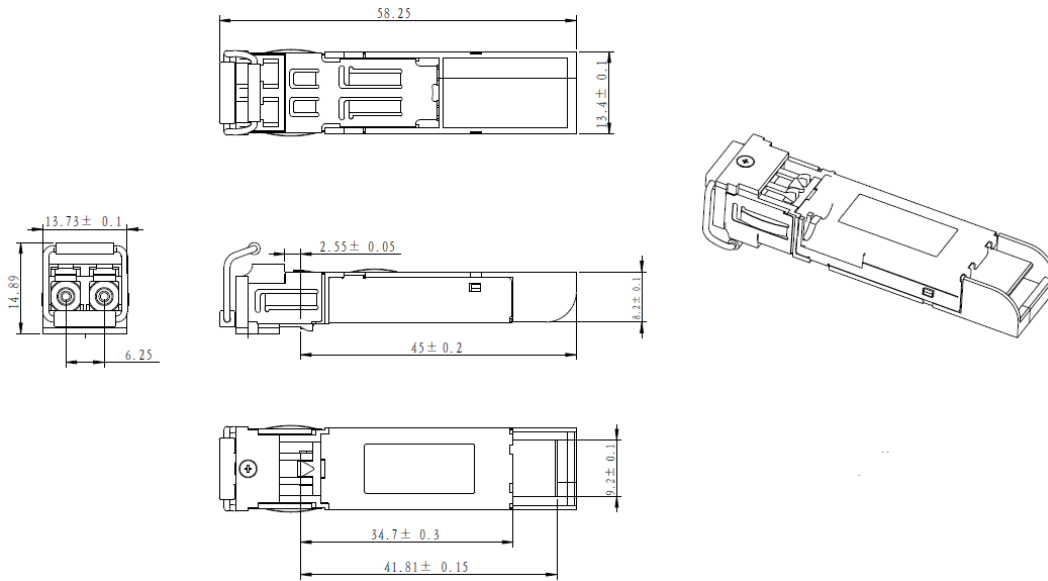

ALL DIMENSIONS ARE ± 0.2 mm UNLESS OTHERWISE SPECIFIED
UNIT: mm

Electrical Pad Layout

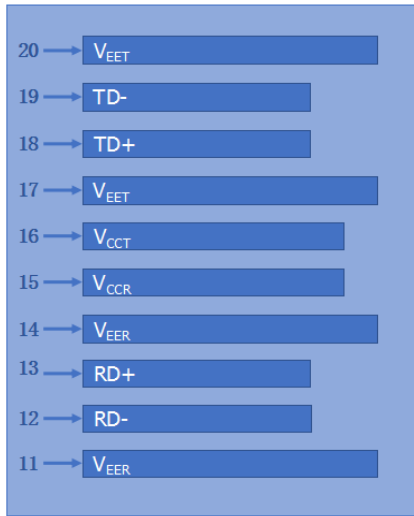

Top of Board

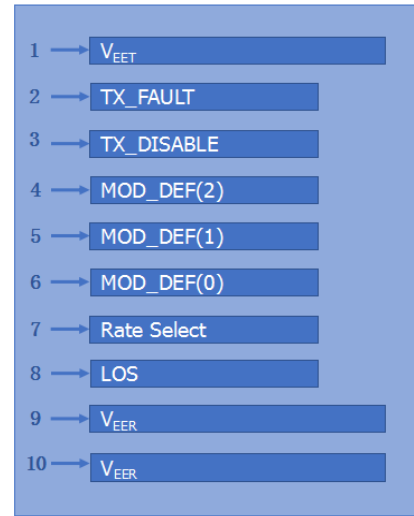

Bottom of Board

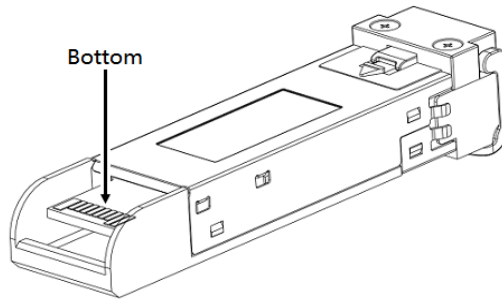
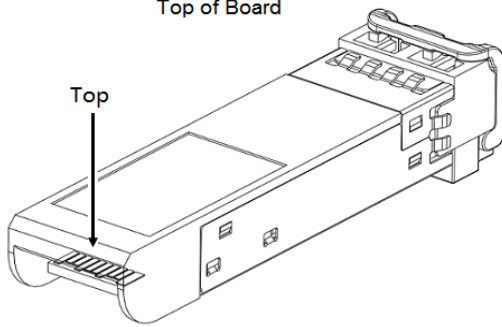

Pin Assignment

PIN #	Symbol	Description	Remarks
1	V _{EET}	Transmitter ground (common with receiver ground)	1
2	TX_FAULT	Transmitter Fault. Not supported	
3	TX_DISABLE	Transmitter Disable. Laser output disabled on high or open	2
4	MOD_DEF(2)	Module Definition 2. Data line for serial ID	3
5	MOD_DEF(1)	Module Definition 1. Clock line for serial ID	3
6	MOD_DEF(0)	Module Definition 0. Grounded within the module	3
7	Rate Select	No connection required	
8	LOS	Loss of Signal indication. Logic 0 indicates normal operation	4
9	V _{EER}	Receiver ground (common with transmitter ground)	1
10	V _{EER}	Receiver ground (common with transmitter ground)	1
11	V _{EER}	Receiver ground (common with transmitter ground)	1
12	RD-	Receiver Inverted DATA out. AC coupled	
13	RD+	Receiver Non-inverted DATA out. AC coupled	
14	V _{EER}	Receiver ground (common with transmitter ground)	1
15	V _{CCR}	Receiver power supply	
16	V _{CCT}	Transmitter power supply	
17	V _{EET}	Transmitter ground (common with receiver ground)	1
18	TD+	Transmitter Non-Inverted DATA in. AC coupled	
19	TD-	Transmitter Inverted DATA in. AC coupled	
20	V _{EET}	Transmitter ground (common with receiver ground)	1

Notes:

1. Circuit ground is isolated from chassis ground
2. Disabled: T_{DIS} > 2V or open, Enabled: T_{DIS} < 0.8V
3. Should Be pulled up with 4.7k – 10k ohm on host board to a voltage between 2V and 3.6V
4. LOS is open collector output

References

1. Small Form Factor Pluggable (SFP) Transceiver Multi-Source Agreement (MSA), September 2000.
2. Bellcore GR-253 and ITU-T G.957 Specifications.