

## DATA SHEET

### MODULETEK: SFP-OC3-SR/IR1-C10

OC-3/STM-1/Fast Ethernet SFP (Small Form Pluggable) Transceiver

#### SFP-OC3-SR/IR1-C10 Overview

ModuleTek's SFP-OC3-SR/IR1-C10 SFP optical transceivers are complying with Fast Ethernet standards at 125Mb/s data rate and ATM/SDH/SONET standards at OC-3 IR-1/STM S-1.1 and OC-3 SR-1/SDH STM I-1(155Mb/s) data rate. The SFP-OC3-SR/IR1-C10 SFP optical transceivers with digital diagnostics monitoring functionality provide a quick and reliable interface for single mode applications. The digital diagnostics functions are available via the 2-wire serial bus. In addition, they comply with the Small Form Factor Pluggable Multi-Source Agreement (MSA).

#### Product Features

- Up to 155 Mb/s bi-directional data links
- Comply to SFP MSA
- Built-in digital diagnostics functions
- Hot-pluggable SFP+ footprint
- Uncooled 1310nm FP laser transmitter
- Duplex LC connector
- Up to 15km on SMF
- Single power supply 3.3V
- RoHS Compliant
- Class 1 laser product complies with EN 60825-1
- Operating temperature range: 0°C to 70°C

#### Applications

- 125Mb/s Fast Ethernet
- SONET OC-3 IR-1/SDH STM S-1.1
- SONET OC-3 SR-1/SDH STM I-1

## Ordering Information

Part Number	Description	Color on Clasp
SFP-OC3-SR/IR1-C10	SONET OC-3 IR-1/SDH STM S-1.1, SONET OC-3 SR-1/SDH STM I-1 and 100BASE-LX SFP, 1310nm, LC Connectors, 15km over SMF. DOM Support.	Yellow
<b>For More Information:</b> ModuleTek Limited Web: <a href="http://www.moduletek.com">www.moduletek.com</a> Email: <a href="mailto:sales@moduletek.com">sales@moduletek.com</a>		

## General Specifications

Parameter	Symbol	Min	Typ	Max	Unit	Remarks
Data Rate	DR	125		155	Mb/s	
Bit Error Rate	BER			$10^{-12}$		
Operating Temperature	T <sub>C</sub>	0		70	°C	1
Storage Temperature	T <sub>STO</sub>	-40		85	°C	2
Supply Current	I <sub>CC</sub>		165	300	mA	3
Input Voltage	V <sub>CC</sub>	3.14	3.3	3.46	V	
Maximum Voltage	V <sub>MAX</sub>	-0.5		4	V	3
Max. Supported Link Length on 9/125µm SMF @ OC-3	L <sub>MAX</sub>		15		km	
Max. Supported Link Length on 9/125µm SMF @ FE	L <sub>MAX</sub>		15		km	

### Notes:

1. Case temperature
2. Ambient temperature
3. For electrical power interface

## Optical – Characteristics – Transmitter

$V_{CC}=3.14V$  to  $3.46V$ ,  $T_C=0^{\circ}C$  to  $70^{\circ}C$

Parameter	Symbol	Min	Typ	Max	Unit	Remarks
Output Optical Power	$P_{TX}$	-15		-8	dBm	1
Optical Center Wavelength	$\lambda_C$	1260		1360	nm	
Extinction Ratio	ER	8.2			dB	
Spectral Width(RMS)	$\Delta\lambda$			7.7	nm	
Optical Rise/Fall Time (20%-80%)	$t_r / t_f$			500	ps	
Relative Intensity Noise	RIN			- 120	dB/Hz	
Generated Jitter (peak to peak)	$GJ_{PP}$			0.07	UI	
Generated Jitter (RMS)	$GJ_{RMS}$			0.007	UI	

### Notes:

1. Average

## Optical – Characteristics – Receiver

$V_{CC}=3.14V$  to  $3.46V$ ,  $T_C=0^{\circ}C$  to  $70^{\circ}C$

Parameter	Symbol	Min	Typ	Max	Unit	Remarks
Optical Center Wavelength	$\lambda_C$	1260		1600	nm	
Receiver Overload	$P_{OL}$	0			dBm	
Average Rx Sensitivity @155Mb/s	$RX\_SEN1$			-28	dBm	1
Average Rx Sensitivity @125Mb/s	$RX\_SEN2$			-28	dBm	1
Optical Rise/Fall Time (20%-80%)	$t_r / t_f$			500	ps	
Generated Jitter (peak to peak)	$GJ_R$			300	ps	
LOS Assert	$LOS_A$	-45			dBm	
LOS De-Assert	$LOS_D$			-28	dBm	
LOS Hysteresis	$LOS_H$	0.5			dB	

### Notes:

- 1.PRBS  $2^{23} - 1$

## Electrical – Characteristics – Transmitter

$V_{CC}=3.14V$  to  $3.46V$ ,  $T_C=0^{\circ}C$  to  $70^{\circ}C$

Parameter	Symbol	Min	Typ	Max	Unit	Remarks
Input differential impedance	$R_{IN}$		100		$\Omega$	
Single ended data input swing	$V_{IN\_PP}$	250		1200	mV	
Transmit disable voltage	$V_D$	$V_{CC}-1.3$		$V_{CC}$	V	
Transmit enable voltage	$V_{EN}$	$V_{EE}$		$V_{EE}+0.8$	V	
Transmit Disable Assert Time				10	us	

## Electrical – Characteristics – Receiver

$V_{CC}=3.14V$  to  $3.46V$ ,  $T_C=0^{\circ}C$  to  $70^{\circ}C$

Parameter	Symbol	Min	Typ	Max	Unit	Remarks
Single ended data output swing	$V_{OUT\_PP}$	300	400	800	mV	
Data output rise time/fall time (20%-80%)	$t_r / t_f$		250	500	ps	
LOS Fault	$V_{LOS\_A}$	$V_{CC}-0.5$		$V_{CC\_HOST}$	V	
LOS Normal	$V_{LOS\_D}$	$V_{EE}$		$V_{EE}+0.5$	V	

## Digital Diagnostic Functions

SFP-OC3-SR/IR1-C10 supports the 2-wire serial communication protocol as defined in SFF-8472. Digital diagnostic information is accessible over the 2-wire interface at the address 0xA2. Digital diagnostics for SFP-OC3-SR/IR1-C10 are internally calibrated by default. The internal micro control unit accesses the device operating parameters in real time, such as transceiver temperature, laser bias current, transmitted optical power, received optical power and transceiver supply voltage. The module implements the alarm function of the SFF-8472, alerts the user when a particular operating parameter exceeds the factory-set normal range.

Parameter	Symbol	Accuracy	Units	Report Range		Unit	Remarks
Internal Calibration							
Temperature	Temp	$\pm 3$	$^{\circ}C$	-40	95	$^{\circ}C$	
Voltage	$V_{CC}$	$\pm 0.1$	V	2.7	3.9	V	
Bias Current	Ibias	$\pm 10$	%	1	80	mA	
Tx Power	$P_{TX}$	$\pm 3$	dB	-18	-5	dBm	
Rx Power	$P_{RX}$	$\pm 3$	dB	-30	0	dBm	

## Block-Diagram-of-Transceiver

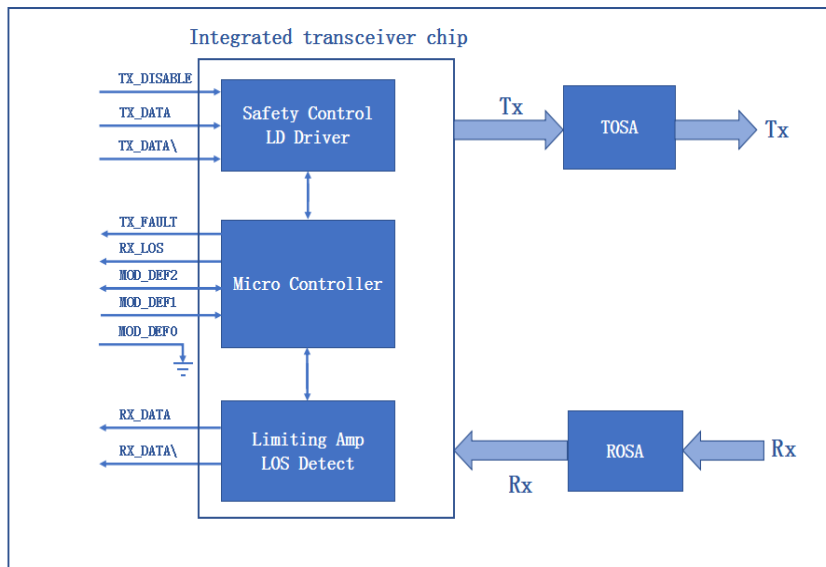

## Functions Description

The transmitter is mainly composed of a laser driver part of the intelligent transceiver chip and a TOSA (light-emitting component), the TOSA includes a 1310nm FP laser and a backlight photodetection chip. When the module is working, the input signal is connected to the intelligent transceiver chip, at this time, the laser driver of the intelligent transceiver chip supplies the bias current and the modulation current to the laser. The intelligent transceiver chip simultaneously uses an automatic optical power control (APC) feedback loop to maintain a constant average optical power of the laser output. The purpose is to eliminate the change of the output optical signal due to temperature changes and aging of the light source device. When the transmitter enable pin (TX\_Disable) is high (TTL logic "1"), the laser output is turned off. When TX\_Disable is low (TTL logic "0"), the laser will turn on within 1ms. When the transmitter fault signal (TX\_Fault) is reported as high, indicates a transmitter failure caused by the transmitter's bias current or transmitted optical power or laser tube temperature exceeding a preset alarm threshold. Low indicates normal operation.

The receiver is mainly composed of a limiting amplifier part of the intelligent transceiver chip and a ROSA (light-receiving component), the ROSA includes a PIN photodetector and a transimpedance amplifier chip. When the ROSA detects the incident light signal, it will be converted into a photo-generated current by the PIN photodetector. The photo-generated current is converted into an electrical signal after passing through the transimpedance amplifier. The electrical signal is further amplified by the limiting amplifier of the intelligent transceiver chip, then outputs a fixed-amplitude electrical signal to the host. When the amplitude of the electrical signal received from the incident light conversion of the opposite optical transceiver module is lower than the set threshold, the module reports that the received signal is lost, the RX\_LOS pin is high (logic "1"), which can be used to diagnose whether the physical signal is normal. The signal is operated in TTL level. The microprocessor inside the module monitors the module's operating voltage, temperature, transmitted optical power, received optical power, and laser bias current value in real time. The host acquires this information over a 2-wire serial bus.

## Dimensions

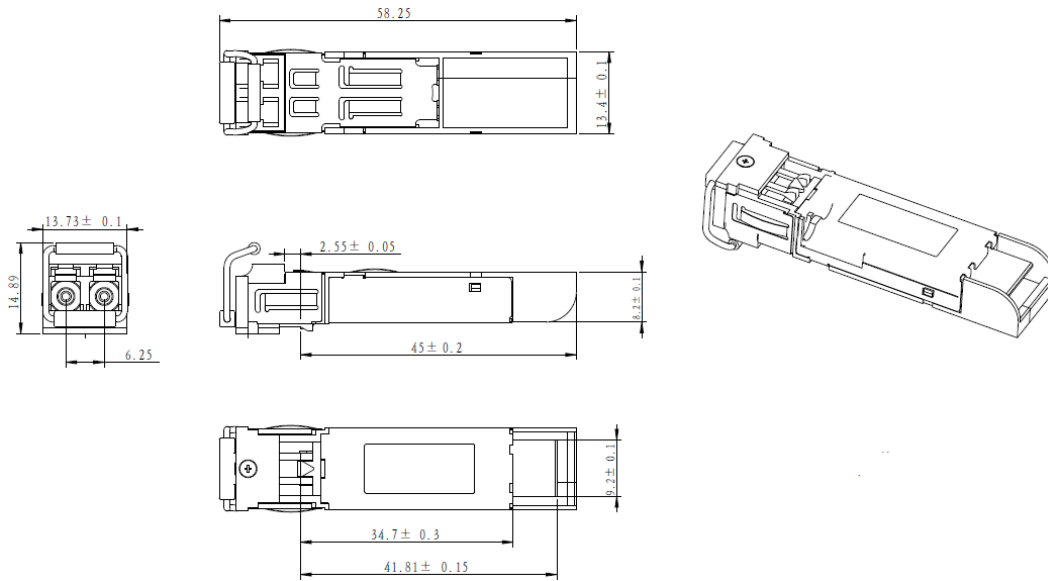

ALL DIMENSIONS ARE ±0.2mm UNLESS OTHERWISE SPECIFIED  
UNIT: mm

## Electrical Pad Layout

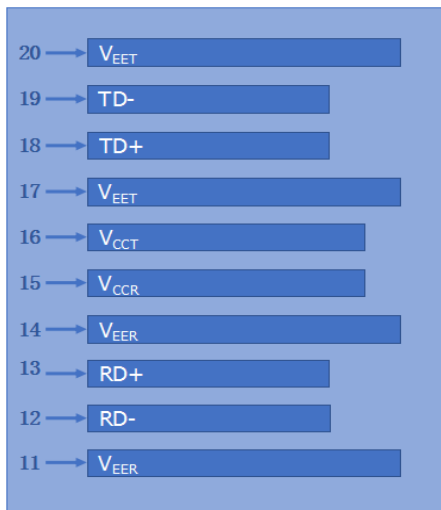

Top of Board

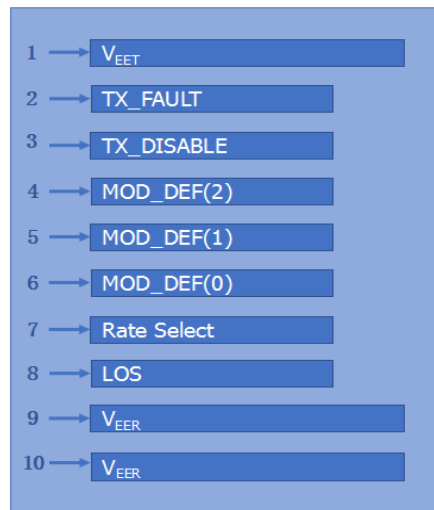

Bottom of Board

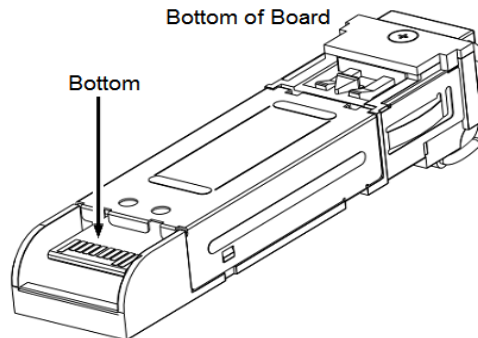
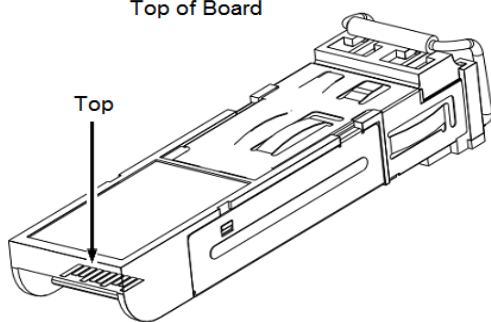

## Pin Assignment

PIN #	Symbol	Description	Remarks
1	V <sub>EET</sub>	Transmitter ground (common with receiver ground)	1
2	TX_FAULT	Transmitter Fault. Not supported	
3	TX_DISABLE	Transmitter Disable. Laser output disabled on high or open	2
4	MOD_DEF(2)	Module Definition 2. Data line for serial ID	3
5	MOD_DEF(1)	Module Definition 1. Clock line for serial ID	3
6	MOD_DEF(0)	Module Definition 0. Grounded within the module	3
7	Rate Select	No connection required	
8	LOS	Loss of Signal indication. Logic 0 indicates normal operation	4
9	V <sub>EER</sub>	Receiver ground (common with transmitter ground)	1
10	V <sub>EER</sub>	Receiver ground (common with transmitter ground)	1
11	V <sub>EER</sub>	Receiver ground (common with transmitter ground)	1
12	RD-	Receiver Inverted DATA out. AC coupled	
13	RD+	Receiver Non-inverted DATA out. AC coupled	
14	V <sub>EER</sub>	Receiver ground (common with transmitter ground)	1
15	V <sub>CCR</sub>	Receiver power supply	
16	V <sub>CCT</sub>	Transmitter power supply	
17	V <sub>EET</sub>	Transmitter ground (common with receiver ground)	1
18	TD+	Transmitter Non-Inverted DATA in. AC coupled	
19	TD-	Transmitter Inverted DATA in. AC coupled	
20	V <sub>EET</sub>	Transmitter ground (common with receiver ground)	1

### Notes:

1. Circuit ground is isolated from chassis ground
2. Disabled: T<sub>DIS</sub> > 2V or open, Enabled: T<sub>DIS</sub> < 0.8V
3. Should Be pulled up with 4.7k – 10k ohm on host board to a voltage between 2V and 3.6V
4. LOS is open collector output

## References

1. IEEE standard 802.3. IEEE Standard Department, 2002.
2. Small Form Factor Pluggable (SFP) Transceiver Multi-Source Agreement (MSA), September 2000.
3. Bellcore GR-253 and ITU-T G.957 Specifications.