

DATA SHEET

MODULETEK –XFP-10GB-CWDM-ZR-xxxx-C10

10 Gigabit CWDM 80km XFP Optical Transceiver

XFP-10GB-CWDM-ZR-xxxx-C10 Overview

ModuleTek' s XFP-10GB-CWDM-ZR-xxxx-C10 10 Gb/s XFP optical transceivers are designed for 10GBASE-ZR, 10GBASE-ZW, 10GFC and OC192 interconnects. The XFP-10GB-CWDM-ZR-xxxx-C10 are compliant with the XFP Multi-Source Agreement (MSA) Specification. The digital diagnostics functions are available via 2-wire serial interface, as specified in the XFP MSA.

Product Features

- Up to 9.95 Gb/s to 11.1 Gb/s bit rates.
- Compliant with 10GBASE–ZR/ZW, 10GFC, OC192 application.
- Compliant with XFP MSA.
- Temperature–stabilized EML laser in CWDM wavelength.
- 30 pin XFP compatible connector.
- Standard bail mechanism for consistent installation and removal
- Built–in digital diagnostic functions.
- Hot Pluggable XFP footprint.
- Duplex LC Connectors.
- Up to 80km on SMF
- RoHS Compliant
- Operating temperature range: 0°C to 70°C

Applications

- 10GBASE–ZR/ZW 10G Ethernet
- 80Km 10G Fiber Channel
- OC192 /STM–64

Ordering Information

Part Number	Description	Color on Clasp
XFP-10GB-CWDM-ZR-1470-C10	10 Gigabit CWDM XFP Transceiver, LC Connectors, 1470nm, Single Mode Fiber 80km	Gray
XFP-10GB-CWDM-ZR-1490-C10	10 Gigabit CWDM XFP Transceiver, LC Connectors, 1490nm, Single Mode Fiber 80km	Violet
XFP-10GB-CWDM-ZR-1510-C10	10 Gigabit CWDM XFP Transceiver, LC Connectors, 1510nm, Single Mode Fiber 80km	Blue
XFP-10GB-CWDM-ZR-1530-C10	10 Gigabit CWDM XFP Transceiver, LC Connectors, 1530nm, Single Mode Fiber 80km	Green
XFP-10GB-CWDM-ZR-1550-C10	10 Gigabit CWDM XFP Transceiver, LC Connectors, 1550nm, Single Mode Fiber 80km	Yellow
XFP-10GB-CWDM-ZR-1570-C10	10 Gigabit CWDM XFP Transceiver, LC Connectors, 1570nm, Single Mode Fiber 80km	Orange
XFP-10GB-CWDM-ZR-1590-C10	10 Gigabit CWDM XFP Transceiver, LC Connectors, 1590nm, Single Mode Fiber 80km	Red
XFP-10GB-CWDM-ZR-1610-C10	10 Gigabit CWDM XFP Transceiver, LC Connectors, 1610nm, Single Mode Fiber 80km	Brown
For More Information: ModuleTek Limited Web: www.moduletek.com Email: sales@moduletek.com		

Absolute Maximum Ratings

Parameter	Symbol	Min	Typ	Max	Unit	Remarks
Storage Ambient Temperature	T _S	-40		85	°C	
Supply Voltage 5V		-0.5		5.5		
Supply Voltage 3.3V	V _{CC3}	-0.5		4	V	

General Specifications

Parameter	Symbol	Min	Typ	Max	Unit	Remarks
Data Rate	DR	9.95		11.1	Gb/s	
Bit Error Rate	BER			10^{-12}		
Total Power Consumption	P			3.5	W	
Supply Voltage -5V	V _{CC5}	4.75		5.25	V	1
Supply Voltage -3.3V	V _{CC3}	3.14		3.46	V	1
Supply Current -V _{CC5} supply	I _{CC5}			350		
Supply Current -V _{CC3} supply	I _{CC3}			700	mA	
Operating Temperature	T _C	0		70	°C	2

Notes:

1. Operating Environment
2. Case temperature

Optical - Characteristics - Transmitter

$V_{CC5}=4.75V$ to $5.25V$, $V_{CC3}=3.14V$ to $3.46V$, $T_C=0^{\circ}C$ to $70^{\circ}C$

Parameter	Symbol	Min	Typ	Max	Unit	Remarks
Output Optical Power	P_{TX}	-4		4	dBm	1
Optical Center Wavelength -1470nm	λ_C	1465	1471	1477	nm	
Optical Center Wavelength -1490nm	λ_C	1485	1491	1497	nm	
Optical Center Wavelength -1510nm	λ_C	1505	1511	1517	nm	
Optical Center Wavelength -1530nm	λ_C	1525	1531	1537	nm	
Optical Center Wavelength -1550nm	λ_C	1545	1551	1557	nm	
Optical Center Wavelength -1570nm	λ_C	1565	1571	1577	nm	
Optical Center Wavelength -1590nm	λ_C	1585	1591	1597	nm	
Optical Center Wavelength -1610nm	λ_C	1605	1611	1617	nm	
Extinction Ratio	ER	8.2			dB	
Side Mode Suppression Ratio	SMSR	30			dB	
Relative Intensity Noise	RIN			-130	dB/Hz	
Transmitter Dispersion Penalty	TDP			3	dB	
Launch Power of OFF Transmitter	P_{OUT_OFF}			-30	dBm	1
Transmitter Jitter (Peak-to-Peak)	TJ			0.1	UI	

Notes:

1.Average

Optical - Characteristics - Receiver

$V_{CC5}=4.75V$ to $5.25V$, $V_{CC3}=3.14V$ to $3.46V$, $T_C=0^{\circ}C$ to $70^{\circ}C$

Parameter	Symbol	Min	Typ	Max	Unit	Remarks
Center Wavelength Range	λ_C	1260		1600	nm	
Optical Input Power	P_{RX}			-7	dBm	
Receiver Sensitivity in (OMA)@10.3Gb/s	R_{X_SEN1}			-24	dBm	1
Receiver Reflectance	TR_{RX}			-27	dB	
LOS Assert	LOS_A	-35			dBm	
LOS De-Assert	LOS_D			-27	dBm	
LOS Hysteresis	LOS_H	0.5			dB	

Notes:

1. Measured with worst ER: $BER < 10^{-12}$; $2^{31} - 1$ PRBS

Electrical - Characteristics - Transmitter

$V_{CC5}=4.75V$ to $5.25V$, $V_{CC3}=3.14V$ to $3.46V$, $T_C=0^{\circ}C$ to $70^{\circ}C$

Parameter	Symbol	Min	Typ	Max	Unit	Remarks
Input differential impedance	R_{IN}		100		Ω	1
Differential data input swing	V_{IN_PP}	120		820	mV	
Transmit Disable Voltage	V_D	2		V_{CC}	V	2
Transmit Enable Voltage	V_{EN}	GND		$GND+0.8$	V	
Transmit Disable Assert Time				10	us	

Notes:

1. After internal AC coupling
2. Or open circuit

Electrical - Characteristics - Receiver

$V_{CC5}=4.75V$ to $5.25V$, $V_{CC3}=3.14V$ to $3.46V$, $T_C=0^{\circ}C$ to $70^{\circ}C$

Parameter	Symbol	Min	Typ	Max	Unit	Remarks
Differential data output swing	V_{OUT_PP}	340	650	850	mV	
Data output rise time (20%-80%)	T_R			38	ps	1
Data output fall time(20%-80%)	T_F			38	ps	1
LOS Fault	V_{LOS_A}	$V_{CC}-0.5$		V_{CC_HOST}	V	
LOS Normal	V_{LOS_D}	GND		$GND+0.5$	V	

Notes:

- 1.20%-80%

Digital Diagnostic Functions

ModuleTek's XFP-10GB-CWDM-ZR-xxxx-C10 incorporates a XFP compliant 2-wire management interface which is used for serial ID, digital diagnostics, and certain control functions. It is modeled on the SFF-8472 Rev 9.3 specification modified to accommodate a single 2-wire interface address. In addition to the basic I2C read/write functionality the modules support packet error checking that, when enabled, allows the host system to confirm the validity of any read data. Details of the protocol and interface are explicitly described in the MSA. And the digital diagnostic functions via a 2-wire serial interface can provide real-time access to following operating parameters:

- a. Transceiver Temperature
- b. Laser Bias Current
- c. Transmitted Optical Power
- d. Received Optical Power
- e. Transceiver Supply Voltage

Block-Diagram-of-Transceiver

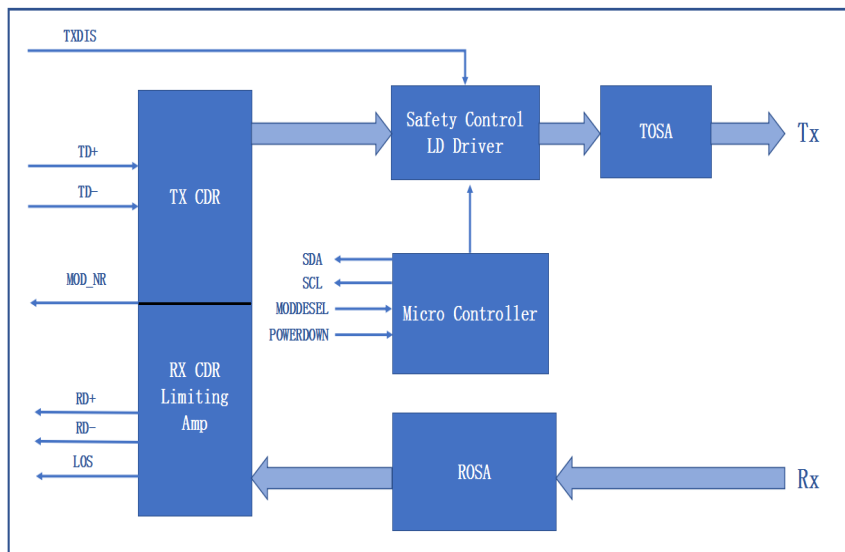

Transmitter Section

The Laser Driver accept differential input data and provide bias and modulation currents for driving a laser. An automatic power control (APC) feedback loop is incorporated to maintain a constant average optical power. Laser in an eye safe optical subassembly (OSA) mates to the fiber cable. TX CDR is used to overcomes host board and connector signal degradations by reshaping, regenerating, and attenuating jitter.

TX_DISABLE

TX_DIS is an input pin. When TX_DIS is asserted High, the XFP module transmitter output must be turned off.

Receiver Section

The Receiver utilizes an APD detector integrated with a trans-impedance preamplifier in an OSA. The OSA is connected to a limiting Amplifier which providing post-amplification quantization, and optical signal detection. The limiting amplifier is AC coupled to the Trans-impedance amplifier, with internal 100ohm differential termination. RX CDR is used to overcomes host board degradations by reshaping, regenerating, and attenuating jitter.

Receive (RX_LOS)

The RX_LOS of an output pin, when LOS is high, it indicates insufficient optical power for reliable signal reception.

MODNR:

The MODNR is an output pin that when High, indicates that the module has detected a condition that renders transmitter and or receiver data invalid, shall consist of logical OR of the following signals:

- f. Transmit Signal Conditioner Loss of Lock
- g. Transmitter Laser Fault
- h. Receiver Signal Conditioner Loss of Lock

Controller Section

The micro controller unit initializes the control register of laser driver, limiting amplifier and CDR. And monitors the running information from the laser driver, limiting amplifier and CDR. Then report these information to the customer.

Dimensions

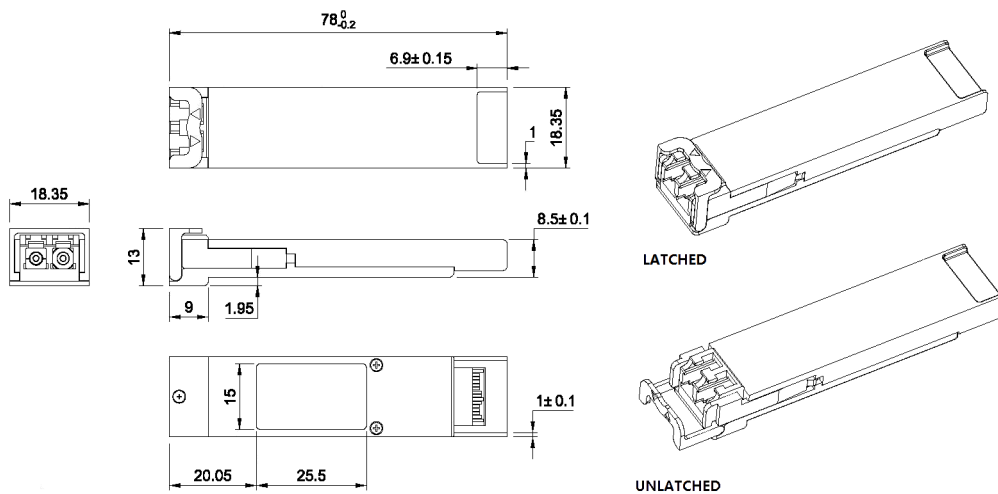

ALL DIMENSIONS ARE ±0.2mm UNLESS OTHERWISE SPECIFIED
UNIT: mm

Electrical Pad Layout

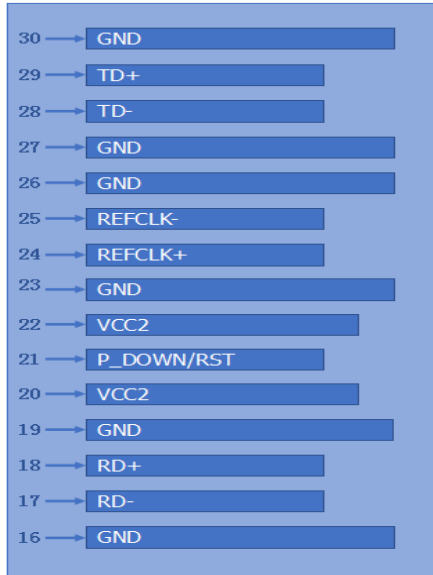

Top of Board

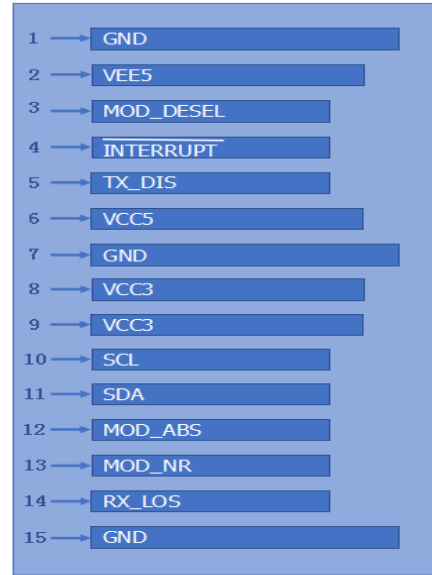

Bottom of Board

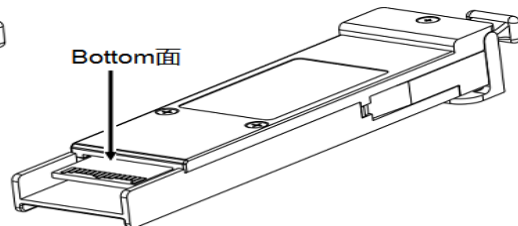
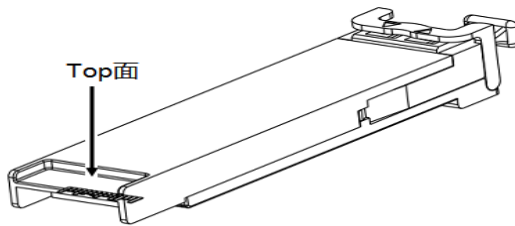

Pin Assignment – Pin1 to Pin30

PIN #	Symbol	Logic	Description	Remarks
1	GND		Module Ground	1
2	VEE5		Optional –5.2 Power Supply (Not required)	
3	Mod–Desel	LVTTTL–I	Module De-select, when held low allows the module to respond to 2-wire serial interface commands	
4	Interrupt	LVTTTL–O	Indicates presence of an important condition which can be read over the serial 2-wire interface	2
5	TX_DIS	LVTTTL-I	Transmitter Disable, Transmitter laser source turned off	
6	VCC5		+5V Power Supply	
7	GND		Module Ground	3
8	VCC3		+3.3V Power Supply	
9	VCC3		+3.3V Power Supply	
10	SCL	LVTTTL-I	Serial 2-wire interface clock	4
11	SDA	LVTTTL-I/O	Serial 2-wire interface data line	4
12	Mod_ABS	LVTTTL-O	Module Absent; Indicates module is not present. Grounded in the module	4
13	Mod_NR	LVTTTL-O	Module Not Ready; Indicates module operating fault	4
14	RX_LOS	LVTTTL-O	Receiver Loss of Signal indicator	4
15	GND		Module Ground	3
16	GND		Module Ground	3
17	RD-	CML-O	Receiver inverted data output	
18	RD+	CML-O	Receiver non-inverted data output	
19	GND		Module Ground	3
20	VCC2		+1.8V Power Supply	
21	P_Down/RST	LVTTTL-I	Power Down; When high, places the module in the low power stand-by mode and on the falling edge of P_Down initiates a module rest	
			Reset; The falling edge initiates a complete reset of the module including the 2-wire serial interface, equivalent to a power cycle	
22	VCC2		+1.8V Power Supply	
23	GND		Module Ground	3
24	RefCLK+	PECL-I	Reference Clock non-inverted input, AC coupled on the host board	

25	RefCLK-	PECL-I	Reference Clock inverted input, AC coupled on the host board	
26	GND		Module Ground	3
27	GND		Module Ground	3
28	TD-	CML-I	Transmitter inverted data input	
29	TD+	CML-I	Transmitter non-inverted data input	
30	GND		Module Ground	3

Notes:

1. Module ground pins (GND) are isolated from the module case and chassis ground within the module
2. Open collector, should be pulled up with 4.7kΩ-10kΩ on host board to a voltage between 3.15V and 3.6V
3. Same as Pin # 1
4. Same as Pin # 4

References

1. 10 Gigabit Small Form Factor Pluggable Module(XFP)Multi-Source Agreement(MSA), Rev4.5 – August 2005.