

DATA SHEET

MODULETEK – XFP-10GB-LR-C10 10 Gigabit 1310nm SingleMode XFP Optical Transceiver

XFP-10GB-LR-C10 Overview

ModuleTek's XFP-10GB-LR-C10 10 Gb/s XFP optical transceivers are designed for the IEEE 802.3ae 10GBASE-LR, 10GBASE-LW and 10GFC 1200-SM-LL-L interconnects. The XFP-10GB-LR-C10 are compliant with the XFP Multi-Source Agreement (MSA) Specification. The digital diagnostics functions are available via 2-wire serial interface, as specified in the XFP MSA.

Product Features

- Up to 11.3 Gb/s bit rates.
- Compliant with IEEE 802.3ae, 10GBASE-LR/LW, 10GFC application.
- Compliant with XFP MSA.
- Uncooled 1310nm DFB laser.
- 30 pin XFP compatible connector.
- Standard bail mechanism for consistent installation and removal
- Built-in digital diagnostic functions.
- Hot Pluggable XFP footprint.
- Duplex LC Connectors.
- Up to 10km on SMF
- RoHS Compliant
- Operating temperature range: 0°C to 70°C.

Applications

- 10GBASE-LR 10G Ethernet
- 10GBASE-LW 10G Ethernet
- 1200-SM-LL-L 10G Fiber Channel

Ordering Information

Part Number	Description
XFP-10GB-LR-C10	10 Gigabit XFP Transceiver, LC Connectors, 1310nm, Single Mode Fiber 10km

For More Information:

ModuleTek Limited

Unit 4A, B Building, Shenfubao S&T Industrial Park, No. 3 Huang Huai Road, Futian Free Trade Zone, Shenzhen, China. 518038.

Email: sales@moduletek.com

Absolute Maximum Ratings

Parameter	Symbol	Min	Typ	Max	Unit	Remarks
Storage Ambient Temperature	T _S	- 40		85	°C	
Supply Voltage 5V		- 0.5		5.5		
Supply Voltage 3.3V	V _{CC_3}	- 0.5		4	V	
Supply Voltage 1.8V	V _{CC_1.8}	- 0.5		2	V	

General Specifications

Parameter	Symbol	Min	Typ	Max	Unit	Remarks
Data Rate	DR	8.5		11.3	Gb/s	1
Bit Error Rate	BER			10 ⁻¹²		
Total Power Consumption	P			1.5	W	
Supply Voltage – 3.3V	V _{CC_3}	3.14		3.46	V	2
Supply Current –V _{CC_3} supply	I _{CC_3}			430	mA	
Case Operating Temperature	T _C	0		70	°C	

Notes:

- 10GBASE-LR/LW 1200-SM-LL-L
- Operating Environment

Link Distances

Parameter	Fiber Type	Distance Range (km)
8.5 – 11.3 Gb/s	9/125um SMF	10

Optical Characteristics - Transmitter

V_{CC_5}=4.75V to 5.25V, V_{CC_3}=3.14V to 3.46V, V_{CC_1.8}=1.71V to 1.89V, T_C=0°C to 70°C

Parameter	Symbol	Min	Typ	Max	Unit	Remarks
Optical Wavelength	λ	1260		1350	nm	
Optical Power	P _{OUT}	- 8		0.5	dBm	1
Launch Power in OMA	P _{OUT_OMA}	- 4.8		0	dBm	
Launch Power of OFF Transmitter	P _{OUT_OFF}			- 30	dBm	1
Side Mode Suppression Ratio	SMSR	30			dB	
Optical Extinction Ratio	ER	3.5			dB	
Relative Intensity Noise	RIN			- 130	dB/Hz	
Transmitter Dispersion Penalty	TDP			3.2	dB	
Transmitter Jitter			According to IEEE 802.3ae requirement			

Notes:

- Average

Optical Characteristics - Receiver

V_{CC_5}=4.75V to 5.25V, V_{CC_3}=3.14V to 3.46V, V_{CC_1.8}=1.71V to 1.89V, T_C=0°C to 70°C

Parameter	Symbol	Min	Typ	Max	Unit	Remarks
Center Wavelength Range	λ_C	1260		1600	nm	
Maximum Optical Input Power	P _{IN}	0.5			dBm	
Receiver Sensitivity in OMA @ 10.3Gb/s	P _{SENS1}			- 12.6	dBm	1
Stressed Receiver Sensitivity in OMA @ 10.3Gb/s	P _{SENS2}			- 10.3	dBm	2
Receiver Reflectance	TR _{RX}			- 12	dB	
LOS De-Assert	LOS _D			- 18	dBm	
LOS Assert	LOS _A	- 35			dBm	
LOS Hysteresis		0.5			dB	

Notes:

1. Measured with worst ER: BER<10⁻¹² 2³¹-1 PRBS
2. IEEE 802.3ae

Electrical Characteristics – Transmitter

V_{CC_5}=4.75V to 5.25V, V_{CC_3}=3.14V to 3.46V, V_{CC_1.8}=1.71V to 1.89V, T_C=0°C to 70°C

Parameter	Symbol	Min	Typ	Max	Unit	Remarks
Input differential impedance	R _{in}		100		Ω	1
Differential data input swing	V _{IN_PP}	120		820	mV	
Transmit Disable Voltage	V _D	2		V _{CC}	V	2
Transmit Enable Voltage	V _{EN}	GND		GND+0.8	V	
Transmit Disable Assert Time				10	us	

Notes:

1. After internal AC coupling
2. Or open circuit

Electrical Characteristics – Receiver

V_{CC_5}=4.75V to 5.25V, V_{CC_3}=3.14V to 3.46V, V_{CC_1.8}=1.71V to 1.89V, T_C=0°C to 70°C

Parameter	Symbol	Min	Typ	Max	Unit	Remarks
Differential data output swing	V _{OUT_PP}	340	650	850	mV	
Data output rise time	T _R			38	ps	1
Data output fall time	T _F			38	ps	1
LOS Fault	V _{LOS_F}	V _{CC} -0.5		V _{CC_HOST}	V	
LOS Normal	V _{LOS_N}	GND		GND+0.5	V	

Notes:

1. 20%-80%

Digital Diagnostic

ModuleTek's XFP-10GB-LR-C10 incorporates a XFP compliant 2-wire management interface which is used for serial ID, digital diagnostics, and certain control functions. It is modeled on the SFF-8472 Rev 9.3 specification modified to accommodate a single 2-wire interface address. In addition to the basic I²C read/write functionality the modules support packet error checking that, when enabled, allows the host system to confirm the validity of any read data. Details of the protocol and interface are explicitly described in the MSA. And the digital diagnostic functions via a 2-wire serial interface can provide real-time access to following operating parameters:

- a. Transceiver Temperature
- b. Laser Bias Current
- c. Transmitted Optical Power
- d. Received Optical Power
- e. Transceiver Supply Voltage

Block Diagram

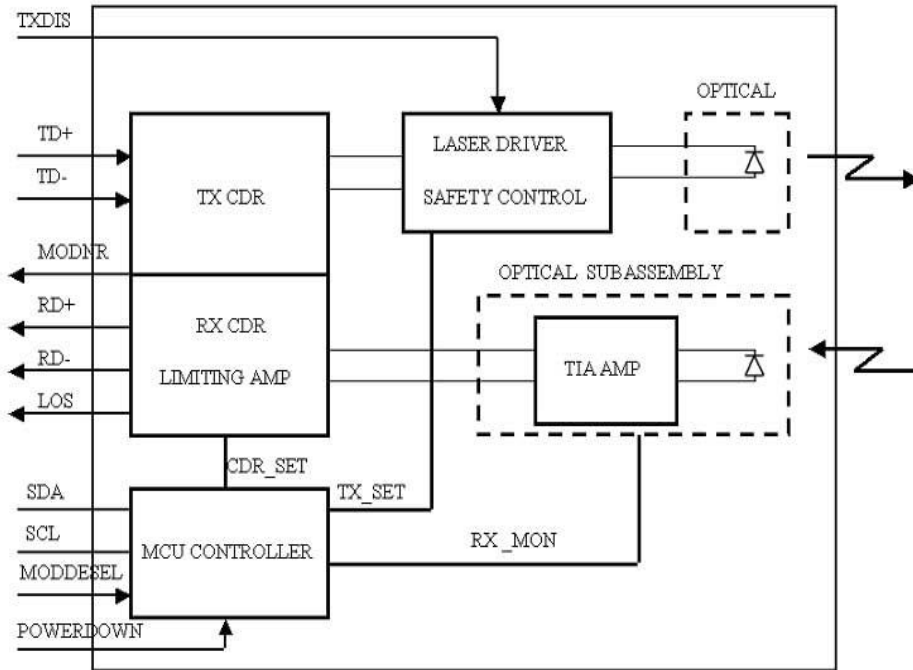

Transmitter Section:

The Laser Driver accepts differential input data and provide bias and modulation currents for driving a laser. An automatic power control (APC) feedback loop is incorporated to maintain a constant average optical power. Laser in an eye safe optical subassembly (OSA) mates to the fiber cable. TX CDR is used to overcomes host board and connector signal degradations by reshaping, regenerating, and attenuating jitter.

TXDIS:

TX_DIS is an input pin. When TX_DIS is asserted High, the XFP module transmitter output must be turned off.

Receiver Section:

The Receiver utilizes a PIN detector integrated with a trans-impedance preamplifier in an OSA. The OSA is connected to a limiting

Amplifier which providing post-amplification quantization, and optical signal detection. The limiting amplifier is AC coupled to the Trans-impedance amplifier, with internal 100ohm differential termination. RX CDR is used to overcomes host board degradations by reshaping, regenerating, and attenuating jitter.

LOS:

The LOS of an output pin, when LOS is high, it indicates insufficient optical power for reliable signal reception.

MODNR:

The MODNR is an output pin that when High, indicates that the module has detected a condition that renders transmitter and or receiver data invalid, shall consist of logical OR of the following signals:

- f. Transmit Signal Conditioner Loss of Lock
- g. Transmitter Laser Fault
- h. Receiver Signal Conditioner Loss of Lock

Controller Section

The micro controller unit initializes the control register of laser driver, limiting amplifier and CDR. And monitors the running information from the laser driver, limiting amplifier and CDR. Then report these information to the customer.

Dimensions

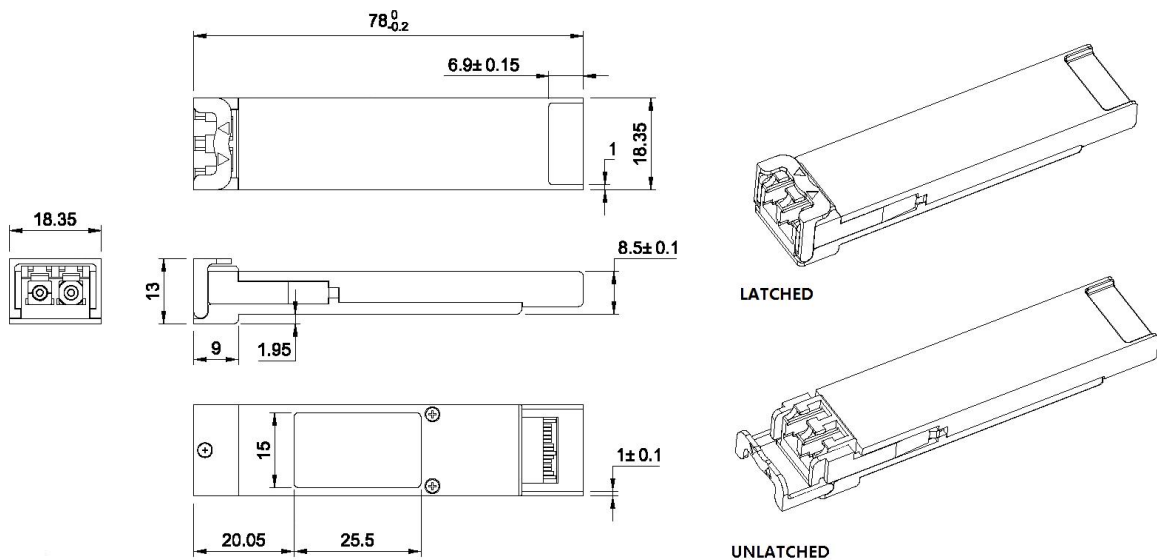

ALL DIMENSIONS ARE ±0.2mm UNLESS OTHERWISE SPECIFIED

UNIT: mm

Pin Assignment – Pin 1 to Pin 23

PIN #	Symbol	Logic	Description	Remarks
1	GND		Module Ground	1
2	VEE5		Optional – 5.2 Power Supply (Not required)	
3	Mod-Desel	LVTTTL-I	Module De-select, when held low allows the module to respond to 2-wire serial interface commands	
4	<u>Interrupt</u>	LVTTTL-O	Indicates presence of an important condition which can be read over the serial 2-wire interface	2
5	TX_DIS	LVTTTL-I	Transmitter Disable, Transmitter laser source turned off	
6	VCC5		+5V Power Supply	
7	GND		Module Ground	3
8	VCC3		+3.3V Power Supply	
9	VCC3		+3.3V Power Supply	
10	SCL	LVTTTL-I	Serial 2-wire interface clock	4
11	SDA	LVTTTL-I/O	Serial 2-wire interface data line	4
12	Mod_ABS	LVTTTL-O	Module Absent; Indicates module is not present. Grounded in the module	4
13	Mod_NR	LVTTTL-O	Module Not Ready; Indicates module operating fault	4
14	RX_LOS	LVTTTL-O	Receiver Loss of Signal indicator	4
15	GND		Module Ground	3
16	GND		Module Ground	3
17	RD-	CML-O	Receiver inverted data output	
18	RD+	CML-O	Receiver non-inverted data output	
19	GND		Module Ground	3
20	VCC2		+1.8V Power Supply	
21	P_Down/RST	LVTTTL-I	Power Down; When high, places the module in the low power stand-by mode and on the falling edge of P_Down initiates a module rest Reset; The falling edge initiates a complete reset of the module including the 2-wire serial interface, equivalent to a power cycle	
22	VCC2		+1.8V Power Supply	
23	GND		Module Ground	3

Notes:

1. Module ground pins (GND) are isolated from the module case and chassis ground within the module
2. Open collector, should be pulled up with 4.7kΩ-10kΩ on host board to a voltage between 3.15V and 3.6V
3. Same as Pin# 1
4. Same as Pin# 4

Pin Assignment – Pin 24 to Pin 30

PIN #	Symbol	Logic	Description	Remarks
24	RefCLK+	PECL-I	Reference Clock non-inverted input, AC coupled on the host board	
25	RefCLK-	PECL-I	Reference Clock inverted input, AC coupled on the host board	
26	GND		Module Ground	1
27	GND		Module Ground	1
28	TD-	CML-I	Transmitter inverted data input	
29	TD+	CML-I	Transmitter non-inverted data input	
30	GND		Module Ground	1

Notes:

1. Same as Pin# 1

Electrical Pad Layout

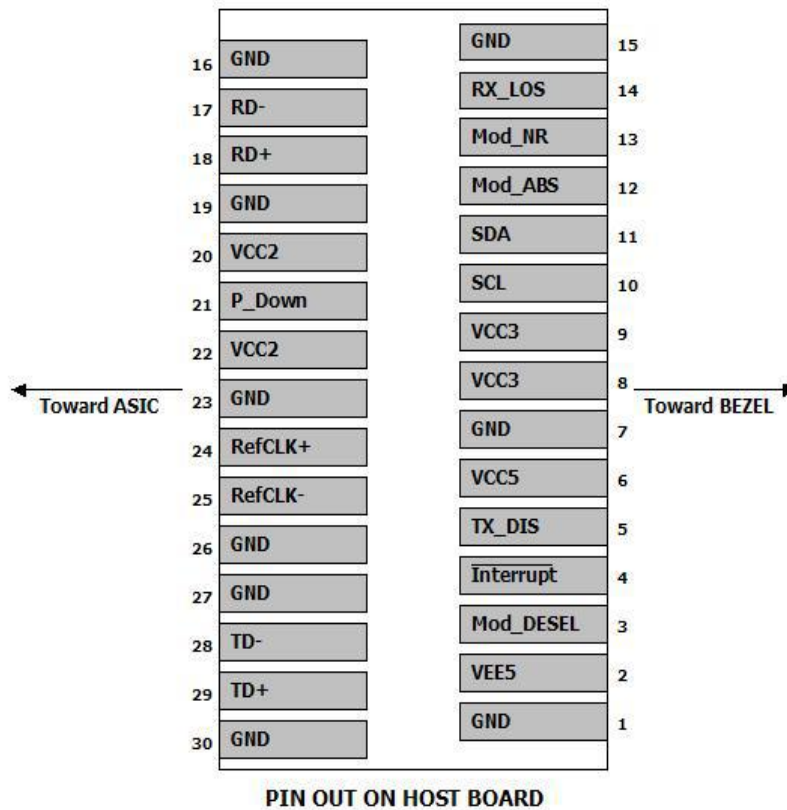

References

1. 10 Gigabit Small Form Factor Pluggable Module (XFP) Multi-Source Agreement (MSA), Rev 4.5 – August 2005.