

## 数据手册

### MODULETEK: DAC-QSFP-2QSFP-100G-P-xxAWG-aa.aaM-D1D1D

#### QSFP 转 2QSFP 100G 无源直连线缆

### 产品简介

ModuleTek 的 QSFP 转 2QSFP 100G 无源线缆是一种高速，经济高效的 100Gbps 转 2x50Gbps 以太网连接解决方案，旨在满足在数据中心不断增长的带宽需求。该产品一侧使用一个 QSFP 端口，另一侧使用两个 QSFP 端口提供系统之间的连接，此互连系统符合 SFF-8665。

### 产品特性

- 符合 SFF-8665 规范
- 2 个独立双工通道，工作速率为 50Gbps
- 3.3V 单电源供电
- BER 优于 1E-15
- 热插拔设计
- 符合 RoHS 标准
- 工作温度范围（外壳温度）：  
商业温度等级：0°C 至 70°C



### 应用

100G 以太网  
光纤通道

## 订购信息

型号	产品 ID	描述	线规	长度
DAC-QSFP-2QSFP-100G-P-30AWG-aa.aaM-D1D1D	M254801	QSFP 转 2QSFP 100G 无源线缆	30AWG	≤3 米
DAC-QSFP-2QSFP-100G-P-26AWG-aa.aaM-D1D1D	M009501	QSFP 转 2QSFP 100G 无源线缆	26AWG	≤5 米
<p><b>注:</b></p> <ol style="list-style-type: none"> <li>“P” 表示无源线缆。</li> <li>“aa.aa” 表示以米为单位的线缆长度。</li> <li>该产品可实现写保护功能。</li> <li>上表中产品的线径是不同长度下的默认值，我们还可以为有特殊要求的客户提供其他线径产品。</li> <li>产品 ID 为我司产品标准型号的简写订货号。</li> </ol>				
<p><b>如需了解更多信息或订购上述产品，请联系:</b></p> <p>电子邮件: <a href="mailto:sales@moduletek.com">sales@moduletek.com</a>            摩泰光电官网: <a href="http://www.moduletek.com">www.moduletek.com</a></p>				

## 产品一般规格

参数	符号	最小值	典型值	最大值	单位	备注
误码率	BER			$10^{-12}$		
工作温度	$T_C$	0		70	°C	1
储存温度	$T_{STO}$	-40		85	°C	2
工作电压	$V_{CC}$	3.14	3.30	3.46	V	

### 注:

1. 外壳表面温度
2. 环境温度

## 标准定义表格

Lower Memory Map (A0h)					
IIC 地址	数据长度	寄存器名称	描述	取值 (HEX)	备注
0	1	Identifier	QSFP28	11	
1-2	2	Status	bit0:Data Not Ready; bit1:IntL; bit2: Flat mem	07 00	
3	1	Channel Status LOS Flag	Latched TX/RX LOS indicator	00	
4	1	Channel Status TxFault Flag	Latched TX fault indicator	00	
5	1	Channel Status Reserved5	Reserved	00	
6	1	Module Monitor Temp AW Flag	Latched temperature alarm/ warning and initialization complete	00	
7	1	Module Monitor Vcc AW Flag	Latched Vcc alarm/warning	00	
8	1	Module Monitor Reserved8	Reserved	00	
9-10	2	Channel Mon RxPower AW Flag	Latched Rx Power alarm/ warning	00 00	
11-12	2	Channel Mon TxBias AW Flag	Latched Tx Bias alarm/warning	00 00	
13-21	9	Channel Mon Reserved13	Reserved	00	
22-23	2	Module Monitor Temp	Internally measured module temperature	00 00	
24-25	2	Module Monitor Reserved24	Reserved	00 00	
26-27	2	Module Monitor Voltage	Internally measured module supply voltage	00 00	

28-33	6	Module Monitor Reserved28	Reserved	00	
34-35	2	Channel Mon Rx1Power	Internally measured RX input power, channel 1	00 00	
36-37	2	Channel Mon Rx2Power	Internally measured RX input power, channel 2	00 00	
38-39	2	Channel Mon Rx3Power	Internally measured RX input power, channel 3	00 00	
40-41	2	Channel Mon Rx4Power	Internally measured RX input power, channel 4	00 00	
42-43	2	Channel Mon Tx1Bias	Internally measured TX bias, channel 1	00 00	
44-45	2	Channel Mon Tx2Bias	Internally measured TX bias, channel 2	00 00	
46-47	2	Channel Mon Tx3Bias	Internally measured TX bias, channel 3	00 00	
48-49	2	Channel Mon Tx4Bias	Internally measured TX bias, channel 4	00 00	
50-81	32	Channel Mon Reserved50	Reserved	00	
82-85	4	Reserved82	Reserved	00	
86	1	Control TxDisable	Txn Read/write bit that allows software disable of transmitters	00	
87	1	Control Rx Rate Select	Rx channel Software Rate Select	00	
88	1	Control Tx Rate Select	Tx channel Software Rate Select	00	
89	1	Control Rx4 App Select	Software Application Select per SFF-8079, Rx Channel 4 (Optional)	00	
90	1	Control Rx3 App Select	Software Application Select per SFF-8079, Rx Channel 3 (Optional)	00	
91	1	Control Rx2 App Select	Software Application Select per SFF-8079, Rx Channel 2 (Optional)	00	
92	1	Control Rx1 App Select	Software Application Select per SFF-8079, Rx Channel 1 (Optional)	00	
93	1	Control Power	Power set to low power mode/ Override of LPMode signal setting the power mode with software	00	
94	1	Control Tx4 App Select	Software Application Select per SFF-8079, Tx Channel 4 (Optional)	00	
95	1	Control Tx3 App Select	Software Application Select per SFF-8079, Tx Channel 3 (Optional)	00	

96	1	Control Tx2 App Select	Software Application Select per SFF-8079, Tx Channel 2 (Optional)	00	
97	1	Control Tx1 App Select	Software Application Select per SFF-8079, Tx Channel 1 (Optional)	00	
98-99	2	Control Reserved98	Reserved	00 00	
100	1	Mask TxRx LOS	Masking bit for TX/RX LOS indicator	00	
101	1	Mask TxFault	Masking bit for TX fault indicator	00	
102	1	Mask Reserved102	Reserved	00	
103	1	Mask Temp AW	Masking bit for Temperature alarm/warning and initialization complete	00	
104	1	Mask Vcc AW	Masking bit for Vcc alarm/warning	00	
105-106	2	Mask Reserved105	Reserved	00 00	
107-109	3	Reserved107	Reserved	00	
110	1	Power	Power Less Than 1W	08	
111-112	2	Reserved111	Reserved	00	
113	1	Channel	Four Channel	10	
114-118	5	Reserved107	Reserved	00	
119-122	4	Password Change Entry Area	Password Change Entry Area (optional)	00 00 00 00	
123-126	4	Password Entry Area	Password Entry Area (Optional)	00 00 00 00	
127	1	Page Select	Page Select Byte	00	
<b>Upper Memory Map Page 00h</b>					
IIC 地址	数据长度	寄存器名称	描述	取值 (HEX)	备注
128	1	Identifier	QSFP28	11	
129	1	Ext. Identifier	CLEI code present in Page 02h	10	
130	1	Connector	No separable connector	23	
131-138	8	Tranceiver	Code for electronic compatibility or optical compatibility	80 00 00 00 00 00 00 00	
139	1	Encoding	(64B66B)	05	
140	1	BR, nominal	Nominal Bit Rate 25.5GB/s	FF	
141	1	Extended RateSelect Compliance	Tags for Extended RateSelect compliance	00	
142	1	Length(SMF)	Link length supported for SMF fiber in km	00	
143	1	Length (E-50μm)	Link length supported for EBW 50/125 μm fiber, units of 2 m	00	

144	1	Length (50 μm)	Link length supported for 50/125 μm fiber, units of 1 m	00	
145	1	Length (62.5 μm)	Link length supported for 62.5/125 μm fiber, units of 1 m	00	
146	1	Length (Copper)	Link length supported for copper, units of 1m	-	
147	1	Device Tech	Copper cable unequalized	A0	
148-163	16	Vendor name	MODULETEK	4D 4F 44 55 4C 45 54 45 4B 20 20 20 20 20 20 20	
164	1	Extended Transceiver	Extended Transceiver Codes for InfiniBand	00	
165-167	3	Vendor OUI	QSFP vendor IEEE company ID	00 00 00	
168-183	16	Vendor PN	Part number in Order information	-	
184-185	2	Vendor rev	Revision level for part number provided by vendor (ASCII)	-	
186-187	2	Wavelength	Nominal laser wavelength (Wavelength = value / 20 in nm)	-	
188-189	2	Wavelength Tolerance	Guaranteed range of laser wavelength (+/- value) from Nominal wavelength. (Wavelength Tol. = value/200 in nm)	-	
190	1	Max Case Temp	Maximum Case Temperature in Degrees C.	46	
191	1	CC BASE	Check code for Base ID Fields (addresses 128-190)	-	
192-195	4	Options	Rate Select, TX Disable, TX Fault, LOS, Warning indicators for: Temperature, VCC, RX power, TX Bias	0B 00 00 00	
196-211	16	Vendor SN	Serial number provided by vendor	Programmed by Factory	
212-219	8	Date Code	Year,Month,Day	Programmed by Factory	
220	1	Diagnostic Monitoring Type	Indicates which types of diagnostic monitoring are implemented (if any) in the Module. Bit 1,0 Reserved	00	
221	1	Enhanced options	Indicates which optional enhanced features are implemented in the Module.	00	
222	1	Reserved	Reserved	-	
223	1	CC EXT	Check code for the Extended ID Fields (addresses 192-222)	-	
224-255	32	Vendor Specific	Vendor Specific EEPROM	-	

Upper Memory Map Page 02h					
IIC 地址	数据长度	寄存器名称	描述	取值 (HEX)	备注
128-255	128	Upper Memory Map	User Code Area	-	
Upper Memory Map Page 8Ah					
IIC 地址	数据长度	寄存器名称	描述	取值 (HEX)	备注
128-131	4	Firmware Version Number[4]	Firmware Version Number	-	
132-135	4	Datasheet Version Number[4]	Datasheet Version Number	-	
136	1	Security Level	Security Level: 00=Normal Mode; 01=User Mode (level 1); 02=Factory Mode (level 2);	-	
137-138	2	Vcc ADC	Vcc ADC	-	
139-140	2	Temp ADC	Temp ADC	-	
Upper Memory Map Page F0h					
IIC 地址	数据长度	寄存器名称	描述	取值 (HEX)	备注
128-131	4	Password1 long	Level 1 Password	00 00 10 11	

**注:**

1. 写入密码区域为只写位, 读出永远为 00000000
2. 模块 A0H 的表 00、表 02 带有写保护功能, 进入安全等级 1 可写

## 用户模式

安全等级 1 缺省密码	密码是否可改	权限
00 00 10 11	是 (A0 TF0)	1、可读写 A0 T00/T02
		2、可读 A0 T8A
		3、可读写 A0 TF0

**注:**

1. 寄存器详情见标准定义表格。

## 线缆规格

参数	符号	最小值	典型值	最大值	单位	备注
线规		30AWG		26AWG	AWG	
线缆阻抗	Z	95	100	105	Ohm	

## 产品重量

参数	符号	典型值	单位	备注
30AWG 产品重量	G <sub>D30</sub>	250	g/PCS	1
26AWG 产品重量	G <sub>D28</sub>	360	g/PCS	1
30AWG 电缆重量	G <sub>C30</sub>	130	g/M	2
26AWG 电缆重量	G <sub>C28</sub>	240	g/M	2
防尘帽重量	G <sub>S</sub>	1.40	g/个	

### 注:

1. DAC-QSFP-2QSFP-100G-P-xxAWG-1M-D1D1D 产品的重量
2. 单位长度电缆重量 (两根)。例如: DAC-QSFP-2QSFP-100G-P-30AWG-3M-D1D1D 的重量为:  
 $250+130*(3-1)+1.4*3=514.2g$

## 标称长度

序号	标称长度 L1 (米)	公差范围 ±(厘米)
1	Length≤2	2
2	2<Length≤4	4
3	4<Length≤5	6



## 外形尺寸

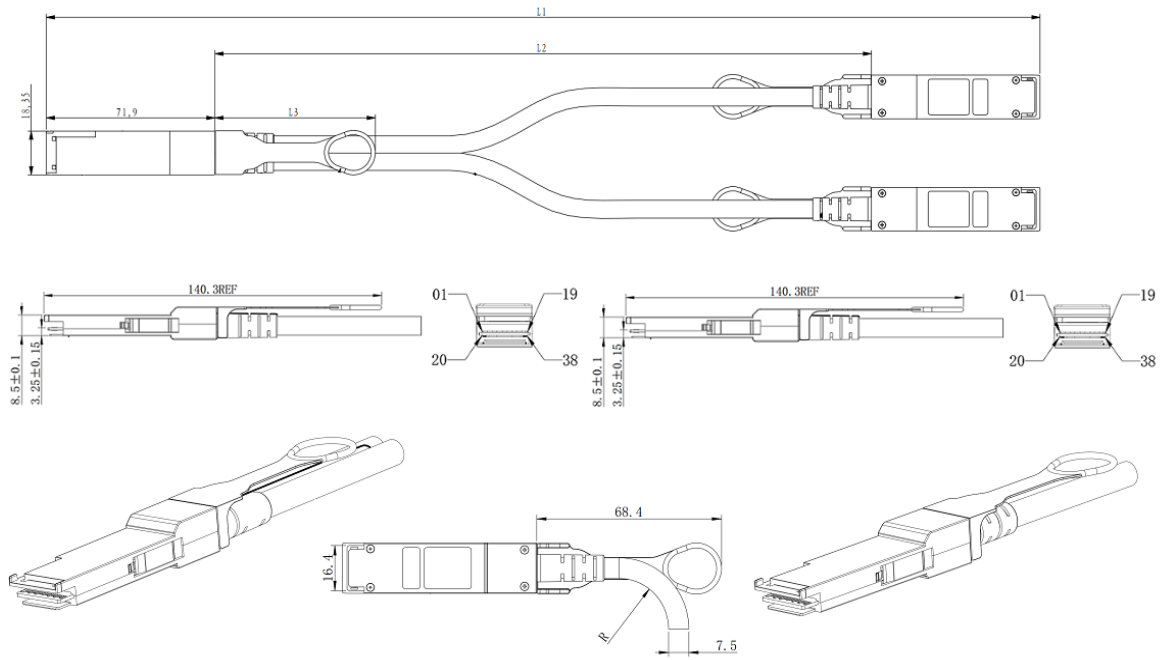

未注尺寸公差  $\pm 0.2\text{mm}$   
单位：毫米

## QSFP 引脚图

顶部视图

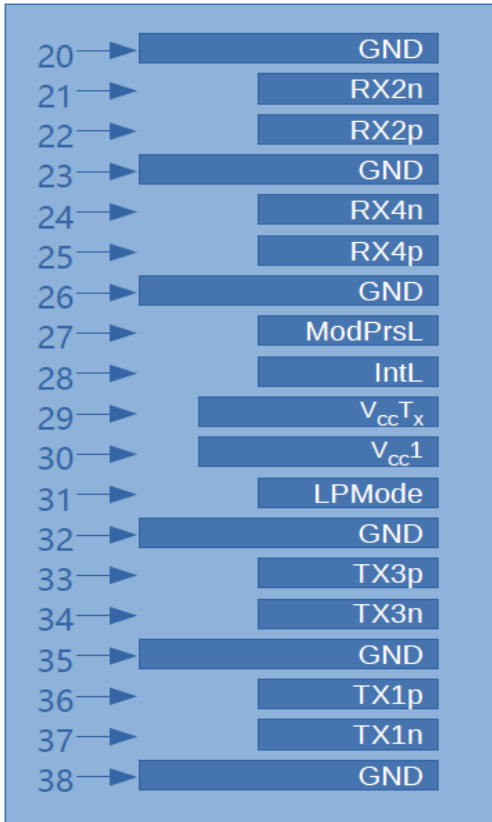

底部视图

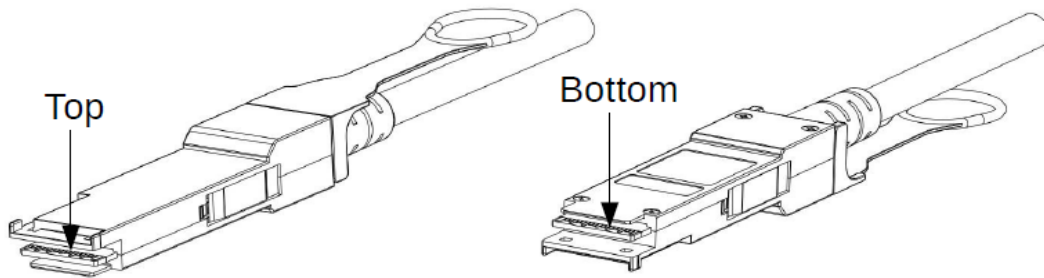
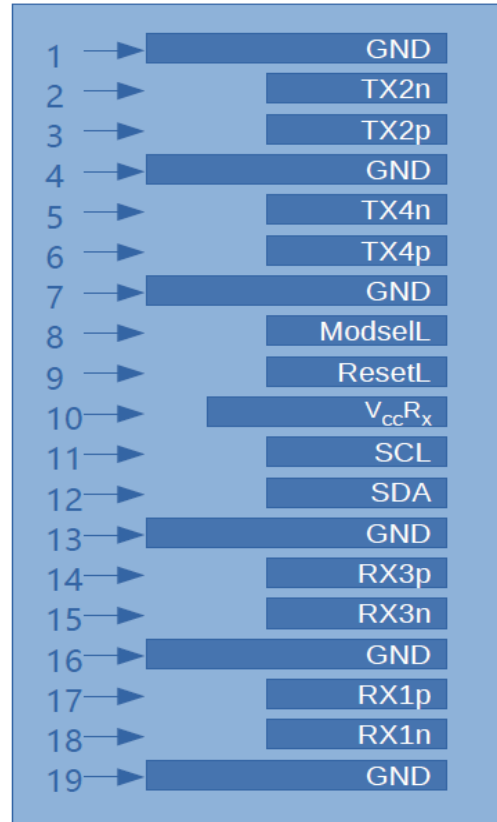

## QSFP 引脚定义

PIN #	符号	说明	备注
1	GND	地	5
2	TX2n	发射端数据输入负, LAN2	
3	TX2p	发射端数据输入正, LAN2	
4	GND	地	5
5	TX4n	发射端数据输入负, LAN4	
6	TX4p	发射端数据输入正, LAN4	
7	GND	地	5
8	ModSelL	模块选择引脚, 低电平时模块响应两线串口通信	1
9	ResetL	模块重置	2
10	V <sub>CC</sub> R <sub>X</sub>	+3.3V 接收端电源供电	
11	SCL	两线串行接口时钟线	
12	SDA	两线串行接口数据线	
13	GND	地	5
14	RX3P	接收端数据输出正, LAN3	
15	RX3n	接收端数据输出负, LAN3	
16	GND	地	5
17	RX1P	接收端数据输出正, LAN1	
18	RX1n	接收端数据输出负, LAN1	
19	GND	地	5
20	GND	地	5
21	Rx2n	接收端数据输出负, LAN2	
22	Rx2p	接收端数据输出正, LAN2	
23	GND	地	5
24	Rx4n	接收端数据输出负, LAN4	
25	Rx4p	接收端数据输出正, LAN4	
26	GND	地	5
27	ModPrsL	模块插入指示管脚, 在模块内接地	3
28	IntL	中断	4
29	V <sub>CC</sub> T <sub>X</sub>	+3.3V 发射端电源供电	
30	V <sub>CC</sub> 1	+3.3V 电源	
31	LPMoDe	低功耗模式	5
32	GND	地	5
33	Tx3p	发射端数据输入正, LAN3	
34	Tx3n	发射端数据输入负, LAN3	
35	GND	地	5
36	Tx1p	发射端数据输入正, LAN1	

37	Tx1n	发射端数据输入负, LAN1	
38	GND	地	5

**注:**

1. ModSelL 是输入引脚。当它通过主机保持低电平时, 模块响应 2 线串行通信命令。ModSelL 允许在单个 2 线接口总线上使用多个 QSFP 模块。如果 ModSelL 为“高”, 模块将不响应来自主机的任何 2 线接口通信。ModSelL 在模块中具有内部上拉电阻。
2. 模块重启引脚, 当 ResetL 引脚上低电平持续时间长于最小脉冲长度时会使模块复位, 并将所有用户模块恢复为它们的默认状态, 在执行复位器件, 主机应忽略所有状态位, 直到模块复位中断完成。
3. 该引脚高电平有效, 表示模块在低功耗模式下运行, 该信号对本产品功能无影响。
4. IntL 是输出引脚, 是开路集电极输出, 应在主机板上以 4.7kΩ-10kΩ 电阻上拉到 Vcc。当它是低电平时, 表示模块可能操作故障。主机使用 2 线串行接口识别中断源。
5. 电路接地与外壳接地内部隔离。

## 参考文献

1. IEEE standard 802.3bj. IEEE Standard Department, 2008.