

## 数据手册

### MODULETEK: DAC-QSFP-2SFP-50G-P-xxAWG-aa.aaM-D1C1B

#### QSFP 转 2SFP 50G 无源直连线缆

### 产品简介

ModuleTek 的 QSFP 转 2SFP 50G 无源线缆是短距离数据传输的优选方案，具有功耗低，稳定性好，性价比高等特点。QSFP 端的四通道关闭其中的两个通道，实现 QSFP 两端口与 2 个 25G SFP 端口之间的数据传输，为数据中心机架内和机架间的数据传输业务提供了一个低成本解决方案。该产品符合 QSFP28 MSA 以及 SFP28 MSA 标准。

### 产品特性

- QSFP 端：符合 QSFP28 MSA 标准
- SFP 端：符合 SFP28 MSA 标准
- 2 通道 25Gbps
- 交流耦合输入和输出
- 100 欧姆差分阻抗
- 全金属外壳，具有出色的 EMI 性能
- 3.3V 单电源供电，低功耗
- 符合 RoHS 标准
- 工作温度范围（外壳温度）：  
商业温度等级：0°C 至 70°C



### 应用

串行数据传输

数据存储

光纤通道

## 订购信息

型号	产品 ID	描述	线规	长度
DAC-QSFP-2SFP-50G-P-30AWG-aa.aaM-D1C1B	M205804	QSFP 转 2SFP 50G 无源线缆, aa.aa $\leq$ 2	30AWG	$\leq$ 2 米
DAC-QSFP-2SFP-50G-P-28AWG-aa.aaM-D1C1B	M205805	QSFP 转 2SFP 50G 无源线缆, aa.aa $\leq$ 3	28AWG	$\leq$ 3 米
DAC-QSFP-2SFP-50G-P-26AWG-aa.aaM-D1C1B	M205806	QSFP 转 2SFP 50G 无源线缆, aa.aa $\leq$ 5	26AWG	$\leq$ 5 米

**注:**

1. “P” 表示无源线缆。
2. “aa.aa” 表示以米为单位的线缆长度。
3. 该产品可实现写保护功能。
4. 上表中产品的线径是不同长度下的默认值, 我们还可以为有特殊要求的客户提供其他线径产品。
5. 产品 ID 为我司产品标准型号的简写订货号。

**如需了解更多信息或订购上述产品, 请联系:**

电子邮件: [sales@moduletek.com](mailto:sales@moduletek.com)  
 摩泰光电官网: [www.moduletek.com](http://www.moduletek.com)

## 产品一般规格

参数	符号	最小值	典型值	最大值	单位	备注
误码率	BER			$10^{-12}$		
工作温度	$T_C$	0		70	°C	1
储存温度	$T_{STO}$	-40		85	°C	2
工作电压	$V_{CC}$	3.14	3.30	3.46	V	

### 注:

1. 外壳表面温度
2. 环境温度

## 标准定义表格

### QSFP 端

Lower Memory Map (A0h)					
IIC 地址	数据长度	寄存器名称	描述	取值 (HEX)	备注
0	1	Identifier	Description of Physical Device	11	
1-2	2	Status	bit0:Data Not Ready; bit1:IntL; bit2: Flat mem	07 00	
3	1	Channel Status LOS Flag	Latched TX/RX LOS indicator	00	
4	1	Channel Status TxFault Flag	Latched TX fault indicator	00	
5	1	Channel Status Reserved5	Reserved	00	
6	1	Module Monitor Temp AW Flag	Latched temperature alarm/ warning and initialization complete	00	
7	1	Module Monitor Vcc AW Flag	Latched Vcc alarm/warning	00	
8	1	Module Monitor Reserved8	Reserved	00	
9-10	2	Channel Mon RxPower AW Flag	Latched Rx Power alarm/ warning	00 00	
11-12	2	Channel Mon TxBias AW Flag	Latched Tx Bias alarm/ warning	00 00	
13-21	9	Channel Mon Reserved13	Reserved	00	
22-23	2	Module Monitor Temp	Internally measured module temperature	00 00	1

24-25	2	Module Monitor Reserved24	Reserved	0000	
26-27	2	Module Monitor Voltage	Internally measured module supply voltage	00 00	1
28-33	6	Module Monitor Reserved28	Reserved	00	
34-35	2	Channel Mon Rx1Power	Internally measured RX input power, channel 1	00 00	
36-37	2	Channel Mon Rx2Power	Internally measured RX input power, channel 2	00 00	
38-39	2	Channel Mon Rx3Power	Internally measured RX input power, channel 3	00 00	
40-41	2	Channel Mon Rx4Power	Internally measured RX input power, channel 4	00 00	
42-43	2	Channel Mon Tx1Bias	Internally measured TX bias, channel 1	00 00	
44-45	2	Channel Mon Tx2Bias	Internally measured TX bias, channel 2	00 00	
46-47	2	Channel Mon Tx3Bias	Internally measured TX bias, channel 3	00 00	
48-49	2	Channel Mon Tx4Bias	Internally measured TX bias, channel 4	00 00	
50-81	32	Channel Mon Reserved50	Reserved	00	
82-85	4	Reserved82	Reserved	00	
86	1	Control TxDisable	Txn Read/write bit that allows software disable of transmitters	00	
87	1	Control Rx Rate Select	Rx channel Software Rate Select	00	
88	1	Control Tx Rate Select	Tx channel Software Rate Select	00	
89	1	Control Rx4 App Select	Software Application Select per SFF-8079, Rx Channel 4 (Optional)	00	
90	1	Control Rx3 App Select	Software Application Select per SFF-8079, Rx Channel 3 (Optional)	00	
91	1	Control Rx2 App Select	Software Application Select per SFF-8079, Rx Channel 2 (Optional)	00	
92	1	Control Rx1 App Select	Software Application Select per SFF-8079, Rx Channel 1 (Optional)	00	

93	1	Control Power	Power set to low power mode/ Override of LPMode signal setting the power mode with software	00	
94	1	Control Tx4 App Select	Software Application Select per SFF-8079, Tx Channel 4 (Optional)	00	
95	1	Control Tx3 App Select	Software Application Select per SFF-8079, Tx Channel 3 (Optional)	00	
96	1	Control Tx2 App Select	Software Application Select per SFF-8079, Tx Channel 2 (Optional)	00	
97	1	Control Tx1 App Select	Software Application Select per SFF-8079, Tx Channel 1 (Optional)	00	
98-99	2	Control Reserved98	Reserved	00 00	
100	1	Mask TxRx LOS	Masking bit for TX/RX LOS indicator	00	
101	1	Mask TxFault	Masking bit for TX fault indicator	00	
102	1	Mask Reserved102	Reserved	00	
103	1	Mask Temp AW	Masking bit for Temperature alarm/warning and initialization complete	00	
104	1	Mask Vcc AW	Masking bit for Vcc alarm/ warning	00	
105-106	2	Mask Reserved105	Reserved	00 00	
107-109	3	Reserved107	Reserved	00	
110	1	Power	Power Less Than 1W	08	
111-112	2	Reserved111	Reserved	00	
113	1	Channel	Four Channel	10	
114-118	5	Reserved107	Reserved	00	
119-122	4	Password Change Entry Area	Password Change Entry Area (optional)	00 00 00 00	
123-126	4	Password Entry Area	Password Entry Area (Optional)	00 00 00 00	2
127	1	Page Select	Page Select Byte	00	
<b>Upper Memory Map Page 00h</b>					
IIC 地址	数据 长度	寄存器名称	描述	取值 (HEX)	备注
128	1	Identifier	QSFP28	11	

129	1	Ext. Identifier	CLEI code present in Page 02h	10	
130	1	Connector	No separable connector	23	
131-138	8	Tranceiver	Code for electronic compatibility or optical compatibility	80 00 00 00 00 00 00 00	
139	1	Encoding	(64B66B)	05	
140	1	BR, nominal	Nominal Bit Rate 25.5GB/s	FF	
141	1	Extended RateSelect Compliance	Tags for Extended RateSelect compliance	00	
142	1	Length(SMF)	Link length supported for SMF fiber in km	00	
143	1	Length (E-50µm)	Link length supported for EBW 50/125 µm fiber, units of 2 m	00	
144	1	Length (50 µm)	Link length supported for 50/125 µm fiber, units of 1 m	00	
145	1	Length (62.5 µm)	Link length supported for 62.5/125 µm fiber, units of 1 m	00	
146	1	Length (Copper)	Link length supported for copper, units of 1m	-	
147	1	Device Tech	Copper cable unequalized	A0	
148-163	16	Vendor name	MODULETEK	4D 4F 44 55 4C 45 54 45 4B 20 20 20 20 20 20 20	
164	1	Extended Transceiver	Extended Transceiver Codes for InfiniBand	00	
165-167	3	Vendor OUI	QSFP vendor IEEE company ID	00 00 00	
168-183	16	Vendor PN	Part number in Order information	-	
184-185	2	Vendor rev	Revision level for part number provided by vendor (ASCII)	-	
186-187	2	Wavelength	Nominal laser wavelength (Wavelength = value / 20 in nm)	-	
188-189	2	Wavelength Tolerance	Guaranteed range of laser wavelength (+/- value) from Nominal wavelength. (Wavelength Tol. = value/200 in nm)	-	

190	1	Max Case Temp	Maximum Case Temperature in Degrees C.	46	
191	1	CC BASE	Check code for Base ID Fields (addresses 128-190)	-	
192-195	4	Options	Rate Select, TX Disable, TX Fault, LOS, Warning indicators for: Temperature, VCC, RX power, TX Bias	0B 00 00 00	
196-211	16	Vendor SN	Serial number provided by vendor	Programmed by Factory	
212-219	8	Date Code	Year,Month,Day	Programmed by Factory	
220	1	Diagnostic Monitoring Type	Indicates which types of diagnostic monitoring are implemented (if any) in the Module. Bit 1,0 Reserved	00	
221	1	Enhanced options	Indicates which optional enhanced features are implemented in the Module.	00	
222	1	Reserved	Reserved	-	
223	1	CC EXT	Check code for the Extended ID Fields (addresses 192-222)	-	
224-255	32	Vendor Specific	Vendor Specific EEPROM	-	
<b>Upper Memory Map Page 02h</b>					
<b>IIC 地址</b>	<b>数据长度</b>	<b>寄存器名称</b>	<b>描述</b>	<b>取值 (HEX)</b>	<b>备注</b>
128-255	128	Upper Memory Map	User Code Area	-	
<b>Upper Memory Map Page 8Ah</b>					
<b>IIC 地址</b>	<b>数据长度</b>	<b>寄存器名称</b>	<b>描述</b>	<b>取值 (HEX)</b>	<b>备注</b>
128-131	4	Firmware Version Number[4]	Firmware Version Number	-	
132-135	4	Datasheet Version Number[4]	Datasheet Version Number	-	
136	1	Security Level	Security Level: 00=Normal Mode; 01=User Mode (level 1); 02=Factory Mode (level 2);	-	
137-138	2	Vcc ADC	Vcc ADC	-	1
139-140	2	Temp ADC	Temp ADC	-	1
<b>Upper Memory Map Page F0h</b>					
<b>IIC 地址</b>	<b>数据长度</b>	<b>寄存器名称</b>	<b>描述</b>	<b>取值 (HEX)</b>	<b>备注</b>

128-131	4	Password1 long	Level 1 Password	00 00 10 11	
---------	---	----------------	------------------	-------------	--

**注:**

1. 模块自动更新数据
2. 缺省为 00000000, 读出为最后的写入值
3. 模块 A0H 的表 00、表 02 带有写保护功能, 进入安全等级 1 可写

**SFP 端**

Address A0					
IIC 地址	数据长度	寄存器名称	描述	取值 (HEX)	备注
0	1	Identifier	SFP or SFP+	03	
1	1	Ext. Identifier	GBIC/SFP function is defined by two-wire interface ID only	04	
2	1	Connector	Copper pigtail	21	
3-10	8	Transceiver	Passive Cable	00 00 00 00 00 04 00 00	
11	1	Encoding	Code for high speed serial encoding algorithm	00	
12	1	BR, Nominal	Nominal Bit Rate 25.5GB/s	FF	
13	1	Rate Identifier	Type of rate select functionality	00	
14	1	Length(SMF,km)	Link length supported for single mode fiber, units of km	00	
15	1	Length (SMF)	Link length supported for single mode fiber, units of 100 m	00	
16	1	Length (50um)	Link length supported for 50 um OM2 fiber, units of 10 m	00	
17	1	Length (62.5um)	Link length supported for 62.5 um OM1 fiber, units of 10 m	00	
18	1	Length (OM4 or copper cable)	Link length supported for 50um OM4 fiber, units of 10m. Alternatively copper or direct attach cable, units of m	01	
19	1	Length (OM3)	Link length supported for 50 um OM3 fiber, units of 10 m	00	
20-35	16	Vendor name	MODULETEK	4D 4F 44 55 4C 45 54 45 4B 20 20 20 20 20 20 20	
36	1	Transceiver	Code for electro nic or optical compatibility	0D	



37-39	3	Vendor OUI	SFP vendor IEEE company ID	00 00 00	
40-55	16	Vendor PN	Part number in Order information	-	
56-59	4	Vendor rev	Revision level for part number provided by vendor (ASCII)	-	
60-61	2	Wavelength	Laser wavelength (Passive/Active Cable Specification Compliance)	00 00	
62	1	Unallocated		00	
63	1	CC BASE	Check code for Base ID Fields (addresses 0 to 62)	-	
64-65	2	Options	Indicates which optional transceiver signals are implemented	00 00	
66	1	BR, max	Upper bit rate margin	64	
67	1	BR, min	Lower bit rate margin	00	
68-83	16	Vendor SN	Serial number provided by vendor	Programmed by Factory	
84-91	8	Date code	Year,Month,Day	Programmed by Factory	
92	1	Diagnostic Monitoring Type	Indicates which type of diagnostic monitoring is implemented (if any) in the transceiver	00	
93	1	Enhanced Options	Indicates which optional enhanced features are implemented (if any) in the transceiver	00	
94	1	SFF-8472 Compliance	Indicates which revision of SFF-8472 the transceiver complies with.	00	
95	1	CC EXT	Check code for the Extended ID Fields (addresses 64 to 94)	-	
96-127	32	Vendor Specific	Vendor Specific EEPROM	-	
128-255	128	Vendor Specific	Vendor Specific EEPROM	-	
<b>Address A2 Low</b>					
IIC 地址	数据长度	寄存器名称	描述	取值 (HEX)	备注
0-94	95	Reserved	Reserved	FF	
95	1	Checksum	0-94 Byte Checksum	-	
96-121	26	Reserved	Reserved	00	

122	1	Security Level	Security Level: 00=Normal Mode; 01=User Mode (Level 1); 02=Factory mode (Level 2);	00	
123-126	4	Password Entry	Password Entry Area	00 00 00 00	1
127	1	Table Selection	Page Select Byte	00	
<b>Address A2 Page 00h/01h</b>					
IIC 地址	数据长度	寄存器名称	描述	取值 (HEX)	备注
128-255	128	Upper Memory Map	User Code Area	-	
<b>Address A2 Page 8Ah</b>					
IIC 地址	数据长度	寄存器名称	描述	取值 (HEX)	备注
128-131	4	Firmware Version Number[4]	Firmware Version Number	-	
132-135	4	Total Running Time In Second	Total Running Time In Second	-	
<b>Address A2 Page F0h</b>					
IIC 地址	数据长度	寄存器名称	描述	取值 (HEX)	备注
128-131	4	Password1 Long	Level 1 Password	00 00 10 11	
132	1	DisableA0WP	00=A0 With Write Protection; 01=A0 Without Write Protection	00	
133	1	DisableA2T00T01WP	00=A2 T00T01 With Write Protection; 01=A2 T00T01 Without Write Protection	00	

### 注:

1. 缺省为 00000000, 读出为最后的写入值
2. 模块的 A0H 及 A2H 的表 00、表 01 带有写保护功能, 进入安全等级 1 可写

## 用户模式

模块	安全等级 1 缺省密码	密码是否可改	权限
QSFP 端	00 00 10 11	是 (A2 TF0)	1、可读写 A0 T00/T02
			2、可读 A0 T8A
			3、可读写 A0 TF0
SFP 端	00 00 10 11	是 (A2 TF0)	1、可读写 A0、A2 T00/T01
			2、可读 A2 T8A
			3、可读写 A2 TF0

## 插损等级

型号	插损等级
DAC-QSFP-2SFP-50G-P-30AWG-1M-D1C1B	CA-25G-N
DAC-QSFP-2SFP-50G-P-30AWG-2M-D1C1B	CA-25G-N
DAC-QSFP-2SFP-50G-P-28AWG-2.5M-D1C1B	CA-25G-N
DAC-QSFP-2SFP-50G-P-28AWG-3M-D1C1B	CA-25G-S
DAC-QSFP-2SFP-50G-P-26AWG-5M-D1C1B	CA-25G-L

### 注:

1. 线缆插损等级分类标准: IEEE 802.3by 110-10

## 线缆规格

参数	符号	最小值	典型值	最大值	单位	备注
线规		30		26	AWG	
线缆阻抗	Z	90	100	110	Ohm	

## 产品重量

参数	符号	典型值	单位	备注
30AWG 产品重量	G <sub>D30</sub>	150	g/PCS	1
28AWG 产品重量	G <sub>D28</sub>	160	g/PCS	1
26AWG 产品重量	G <sub>D26</sub>	170	g/PCS	1
30AWG 电缆重量	G <sub>C30</sub>	64	g/M	2
28AWG 电缆重量	G <sub>C28</sub>	76	g/M	2
26AWG 电缆重量	G <sub>C26</sub>	86	g/M	2
SFP 端防尘帽重量	G <sub>S</sub>	0.80	g/个	
QSFP 端防尘帽重量	G <sub>Q</sub>	1.40	g/个	

### 注:

- DAC-QSFP-2SFP-50G-P-xxAWG-1M-D1C1B 产品的重量
- 单位长度电缆重量 (2 根)。例如: DAC-QSFP-2SFP-50G-P-26AWG-5M-D1C1B 产品的重量为:  
 $170+86*(5-1)+0.80*2+1.40=517.0g$

## 外形尺寸

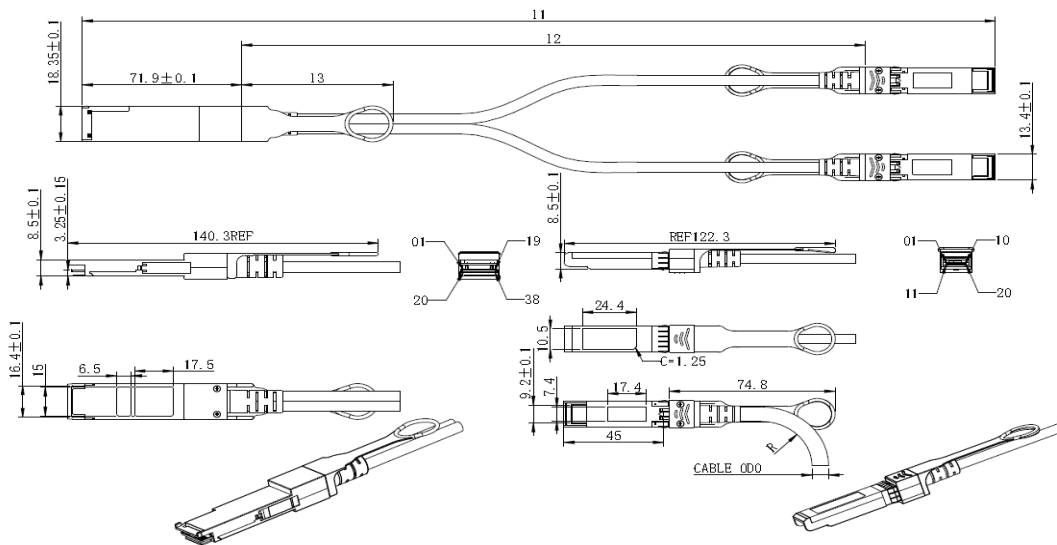

未注尺寸公差 ±0.2mm  
单位：毫米

## 线径尺寸

序号	标准线规 AWG	线缆直径 OD(毫米)	最小弯曲半径 R(毫米)
1	30	4.6	26
2	28	5.0	28
3	26	5.6	30

## 标称长度

序号	模块标称长度 L1 (厘米)	公差范围 (厘米)
1	$L1 \leq 2$	2
2	$2 < L1 \leq 4$	4
3	$4 < L1 \leq 5$	6

## QSFP 引脚图

顶部视图

20	→	GND
21	→	RX2n
22	→	RX2p
23	→	GND
24	→	RX4n
25	→	RX4p
26	→	GND
27	→	ModPrsL
28	→	IntL
29	→	V <sub>cc</sub> T <sub>x</sub>
30	→	V <sub>cc</sub> 1
31	→	LPMode
32	→	GND
33	→	TX3p
34	→	TX3n
35	→	GND
36	→	TX1p
37	→	TX1n
38	→	GND

底部视图

1	→	GND
2	→	TX2n
3	→	TX2p
4	→	GND
5	→	TX4n
6	→	TX4p
7	→	GND
8	→	Modsell
9	→	ResetL
10	→	V <sub>cc</sub> R <sub>x</sub>
11	→	SCL
12	→	SDA
13	→	GND
14	→	RX3p
15	→	RX3n
16	→	GND
17	→	RX1p
18	→	RX1n
19	→	GND

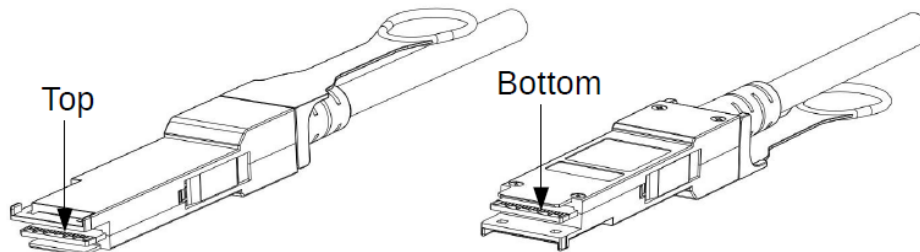

## SFP 引脚图

顶部视图

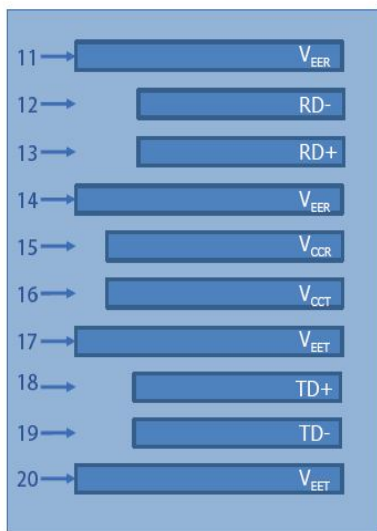

底部视图

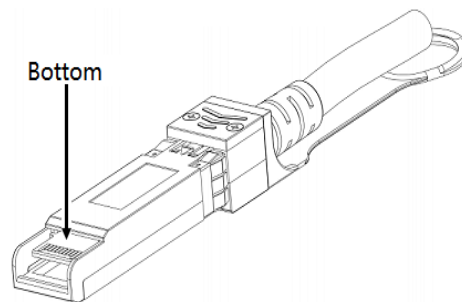
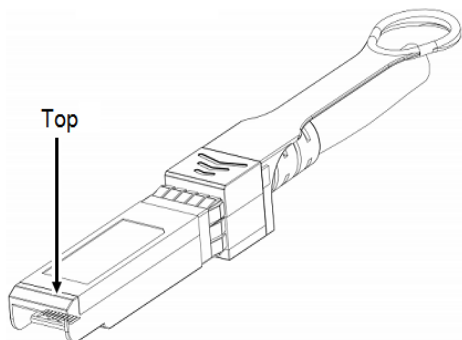
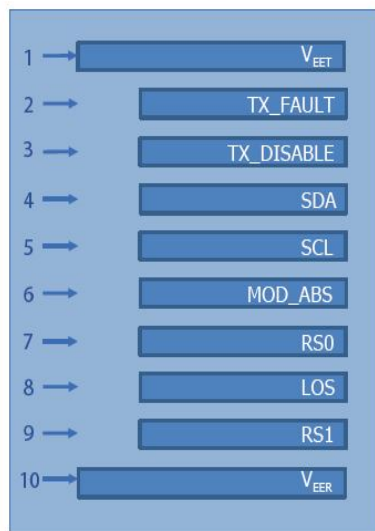

## QSFP 引脚定义

PIN #	符号	说明	备注
1	GND	地	5
2	TX2n	发射端数据输入负, LAN2	
3	TX2p	发射端数据输入正, LAN2	
4	GND	地	5
5	TX4n	发射端数据输入负, LAN4	
6	TX4p	发射端数据输入正, LAN4	
7	GND	地	5
8	ModSelL	模块选择引脚, 低电平时模块响应两线串口通信	1
9	ResetL	模块重置	2
10	V <sub>CC</sub> R <sub>X</sub>	+3.3V 接收端电源供电	
11	SCL	两线串行接口时钟线	
12	SDA	两线串行接口数据线	
13	GND	地	5
14	RX3P	接收端数据输出正, LAN3	
15	RX3n	接收端数据输出负, LAN3	
16	GND	地	5
17	RX1P	接收端数据输出正, LAN1	
18	RX1n	接收端数据输出负, LAN1	
19	GND	地	5
20	GND	地	5
21	Rx2n	接收端数据输出负, LAN2	
22	Rx2p	接收端数据输出正, LAN2	
23	GND	地	5
24	Rx4n	接收端数据输出负, LAN4	
25	Rx4p	接收端数据输出正, LAN4	
26	GND	地	5
27	ModPrsL	模块插入指示引脚, 在模块内接地	3
28	IntL	中断	4
29	V <sub>CC</sub> T <sub>X</sub>	+3.3V 发射端电源供电	
30	V <sub>CC</sub> 1	+3.3V 电源	
31	LPMoDe	低功耗模式	5
32	GND	地	5
33	Tx3p	发射端数据输入正, LAN3	

34	Tx3n	发射端数据输入负, LAN3	
35	GND	地	5
36	Tx1p	发射端数据输入正, LAN1	
37	Tx1n	发射端数据输入负, LAN1	
38	GND	地	5

**注:**

1. ModSelL 是输入引脚。当它通过主机保持低电平时, 模块响应 2 线串行通信命令。ModSelL 允许在单个 2 线接口总线上使用多个 QSFP 模块。如果 ModSelL 为“高”, 模块将不响应来自主机的任何 2 线接口通信。ModSelL 在模块中具有内部上拉电阻。
2. 模块重启引脚, 当 ResetL 引脚上低电平持续时间长于最小脉冲长度时会使模块复位, 并将所有用户模块恢复为它们的默认状态, 在执行复位器件, 主机应忽略所有状态位, 直到模块复位中断完成。
3. 该引脚高电平有效, 表示模块在低功耗模式下运行, 该信号对本产品功能无影响。
4. IntL 是输出引脚, 是开路集电极输出, 应在主机板上以 4.7kΩ-10kΩ 电阻上拉到 Vcc。当它是低电平时, 表示模块可能操作故障。主机使用 2 线串行接口识别中断源。
5. 电路接地与外壳接地内部隔离。



## SFP 引脚定义

PIN #	符号	说明	备注
1	V <sub>EET</sub>	发射端地 (与接收端地共用)	1
2	TX_FAULT	发射端故障告警, 未使用	
3	TX_DISABLE	该信号在高电平或开路时关闭模块发射端, 未使用	
4	SDA	两线串行接口数据线	2
5	SCL	两线串行接口时钟线	2
6	MOD_ABS	模块插入指示引脚, 在模块内接地	2
7	RS0	未连接	
8	LOS	信号丢失指示, 低电平表示模块正常工作, 内部接地	
9	RS1	未连接	
10	V <sub>EER</sub>	接收端地 (与发射端地共用)	1
11	V <sub>EER</sub>	接收端地 (与发射端地共用)	1
12	RD-	接收端数据输出负, 交流耦合	
13	RD+	接收端数据输出正, 交流耦合	
14	V <sub>EER</sub>	接收端地 (与发射端地共用)	1
15	V <sub>CCR</sub>	接收端电源	
16	V <sub>CCT</sub>	发射端电源	
17	V <sub>EET</sub>	发射端地 (与接收端地共用)	1
18	TD+	发射端数据输入正, 交流耦合	
19	TD-	发射端数据输入负, 交流耦合	
20	V <sub>EET</sub>	发射端地 (与接收端地共用)	1

## 注:

1. 电路地与模块外壳是绝缘的。
2. 应在主机板上以 4.7kΩ-10kΩ 的电阻上拉到 2V 至 3.6V 之间的电压。

## 参考文献

1. IEEE standard 802.3bj. IEEE Standard Department.
2. IEEE standard 802.3by. IEEE Standard Department.