

数据手册

MODULETEK: DAC-QSFP-4SFP-40G-A-xxAWG-aa.aaM-D0C0B

QSFP 转 4SFP 40G 有源线缆

产品简介

ModuleTek 的 QSFP 转 4SFP 40G 有源线缆四条线路均能以高达 10Gbps 的速率传输数据，提供 40Gbps 的聚合速率。在短距离的传输数据方面性能优秀，并且功耗低，性价比高。QSFP 转 4SFP 有源线缆为 10G 以太网、数据存储中心、计算中心等机架与机架间的数据传输提供了一种低成本解决方案。QSFP 转 4SFP 有源线缆完全符合 SFF-8436、QSFP+ MSA 以及 IEEE 802.3ae 标准。

产品特性

- QSFP 端：符合 QSFP+ MSA 标准
- SFP 端：符合 SFP+ MSA 标准
- QSFP 端：缺省带压制，软件可配置
- SFP 端：缺省不带压制功能，软件可配置
- 以 10Gbps 速率运行的 4 个独立双工通道
- 支持 2.5Gbps 和 5Gbps 数据速率
- 全金属外壳，具有良好的 EMI 性能
- 单电源供电 3.3V，低功耗
- 符合 RoHS 标准
- 工作温度范围（外壳温度）：
商业温度等级：0°C 至 70°C

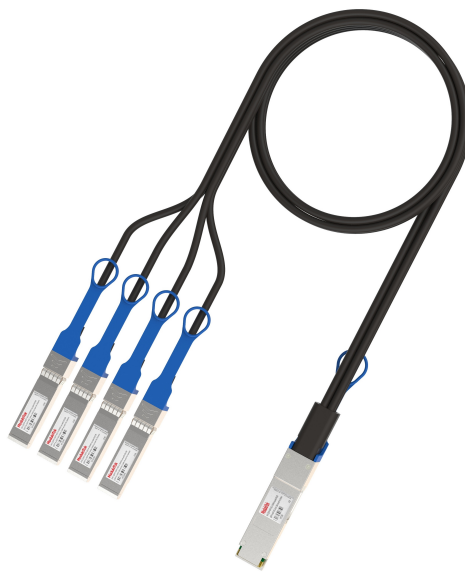

应用

10G/40G 以太网
串行数据传输
数据存储
光纤通道
交换机、路由器

订购信息

型号	产品 ID	描述	线规	长度
DAC-QSFP-4SFP-40G-A-30AWG-aa.aaM-D0C0B	M358705	QSFP 转 4SFP 40G 有源线缆, aa.aa \leq 7	30AWG	\leq 7 米
DAC-QSFP-4SFP-40G-A-28AWG-aa.aaM-D0C0B	M430105	QSFP 转 4SFP 40G 有源线缆, aa.aa \leq 10	28AWG	\leq 10 米
<p>注:</p> <ol style="list-style-type: none"> 1. "A" 表示有源线缆 2. "aa.aa" 表示以米为单位的线缆长度 3. 该产品可实现写保护功能 4. 上表中产品的线径是不同长度下的默认值, 我们还可以为有特殊要求的客户提供其他线径产品 5. 产品 ID 为我司产品标准型号的简写订货号 				
<p>如需了解更多信息或订购上述产品, 请联系:</p> <p>电子邮件: sales@moduletek.com 摩泰光电官网: www.moduletek.com</p>				

产品一般规格

参数	符号	最小值	典型值	最大值	单位	备注
误码率	BER			10^{-12}		
工作温度	T_C	0		70	°C	1
储存温度	T_{STO}	-40		85	°C	2
工作电压	V_{CC}	3.14	3.30	3.46	V	

注:

1. 外壳表面温度
2. 环境温度

标准定义表格

QSFP 端

Lower Memory Map (A0h)					
IIC 地址	数据长度	寄存器名称	描述	取值 (HEX)	备注
0	1	Identifier	QSFP+	0D	
1-2	2	Status	bit0:Data Not Ready; bit1:IntL; bit2: Flat mem	00 00	
3	1	Channel Status LOS Flag	Latched TX/RX LOS indicator	00	
4	1	Channel Status TxFault Flag	Latched TX fault indicator	00	
5	1	Channel Status Reserved5	Reserved	00	
6	1	Module Monitor Temp AW Flag	Latched temperature alarm/ warning and initialization complete	00	
7	1	Module Monitor Vcc AW Flag	Latched Vcc alarm/warning	00	
8	1	Module Monitor Reserved8	Reserved	00	
9-10	2	Channel Mon RxPower AW Flag	Latched Rx Power alarm/ warning	00 00	
11-12	2	Channel Mon TxBias AW Flag	Latched Tx Bias alarm/ warning	00 00	
13-21	9	Channel Mon Reserved13	Reserved	00	
22-23	2	Module Monitor Temp	Internally measured module temperature	11 D6	

24-25	2	Module Monitor Reserved24	Reserved	00 00	
26-27	2	Module Monitor Voltage	Internally measured module supply voltage	80 BB	
28-33	6	Module Monitor Reserved28	Reserved	00	
34-35	2	Channel Mon Rx1Power	Internally measured RX input power, channel 1	00 00	
36-37	2	Channel Mon Rx2Power	Internally measured RX input power, channel 2	00 00	
38-39	2	Channel Mon Rx3Power	Internally measured RX input power, channel 3	00 00	
40-41	2	Channel Mon Rx4Power	Internally measured RX input power, channel 4	00 00	
42-43	2	Channel Mon Tx1Bias	Internally measured TX bias, channel 1	00 00	
44-45	2	Channel Mon Tx2Bias	Internally measured TX bias, channel 2	00 00	
46-47	2	Channel Mon Tx3Bias	Internally measured TX bias, channel 3	00 00	
48-49	2	Channel Mon Tx4Bias	Internally measured TX bias, channel 4	00 00	
50-81	32	Channel Mon Reserved50	Reserved	00	
82-85	4	Reserved82	Reserved	00	
86	1	Control TxDisable	Txn Read/write bit that allows software disable of transmitters	00	
87	1	Control Rx Rate Select	Rx channel Software Rate Select	00	
88	1	Control Tx Rate Select	Tx channel Software Rate Select	00	
89	1	Control Rx4 App Select	Software Application Select per SFF-8079, Rx Channel 4 (Optional)	00	
90	1	Control Rx3 App Select	Software Application Select per SFF-8079, Rx Channel 3 (Optional)	00	
91	1	Control Rx2 App Select	Software Application Select per SFF-8079, Rx Channel 2 (Optional)	00	
92	1	Control Rx1 App Select	Software Application Select per SFF-8079, Rx Channel 1 (Optional)	00	

93	1	Control Power	Power set to low power mode/Override of LPMode signal setting the power mode with software	00	
94	1	Control Tx4 App Select	Software Application Select per SFF-8079, Tx Channel 4 (Optional)	00	
95	1	Control Tx3 App Select	Software Application Select per SFF-8079, Tx Channel 3 (Optional)	00	
96	1	Control Tx2 App Select	Software Application Select per SFF-8079, Tx Channel 2 (Optional)	00	
97	1	Control Tx1 App Select	Software Application Select per SFF-8079, Tx Channel 1 (Optional)	00	
98-99	2	Control Reserved98	Reserved	00 00	
100	1	Mask TxRx LOS	Masking bit for TX/RX LOS indicator	00	
101	1	Mask TxFault	Masking bit for TX fault indicator	00	
102	1	Mask Reserved102	Reserved	00	
103	1	Mask Temp AW	Masking bit for Temperature alarm/warning and initialization complete	00	
104	1	Mask Vcc AW	Masking bit for Vcc alarm/warning	00	
105-106	2	Mask Reserved105	Reserved	00 00	
107-118	12	Reserved107	Reserved	00	
119-122	4	Password Change Entry Area	Password Change Entry Area (optional)	00 00 00 00	
123-126	4	Password Entry Area	Password Entry Area (Optional)	FF FF FF FF	
127	1	Page Select	Page Select Byte	00	
Upper Memory Map Page 00h					
IIC 地址	数据长度	寄存器名称	描述	取值 (HEX)	备注
128	1	Identifier	QSFP+	0D	
129	1	Ext. Identifier	Extended Identifier of Serial Module	00	
130	1	Connector	No separable connector	23	
131-138	8	Tranceiver	40G Active Cable	00 00 00 00 00 00 00 00	

139	1	Encoding	(64B66B)	05	
140	1	BR, nominal	Nominal Bit Rate 10.3Gb/s	67	
141	1	Extended RateSelect Compliance	Tags for Extended RateSelect compliance	00	
142	1	Length(SMF)	Link length supported for SMF fiber in km	00	
143	1	Length (E-50µm)	Link length supported for EBW 50/125 µm fiber, units of 2 m	00	
144	1	Length (50 µm)	Link length supported for 50/125 µm fiber, units of 1 m	00	
145	1	Length (62.5 µm)	Link length supported for 62.5/125 µm fiber, units of 1 m	00	
146	1	Length (Copper)	Link length supported for copper, units of 1m	-	
147	1	Device Tech	Copper cable unequalized	A0	
148-163	16	Vendor name	MODULETEK	4D 4F 44 55 4C 45 54 45 4B 20 20 20 20 20 20 20	
164	1	Extended Transceiver	Extended Transceiver Codes for InfiniBand	00	
165-167	3	Vendor OUI	QSFP vendor IEEE company ID	00 00 00	
168-183	16	Vendor PN	Part number in Order information	-	
184-185	2	Vendor rev	Revision level for part number provided by vendor (ASCII)	-	
186-187	2	Wavelength	Nominal laser wavelength (Wavelength = value / 20 in nm)	-	
188-189	2	Wavelength Tolerance	Guaranteed range of laser wavelength (+/- value) from Nominal wavelength. (Wavelength Tol. = value/ 200 in nm)	-	
190	1	Max Case Temp	Maximum case temperature in degrees C(70°C)	46	
191	1	CC BASE	Check code for Base ID Fields (addresses 128-190)	-	

192-195	4	Options	Rate Select, TX Disable, TX Fault, LOS, Warning indicators for: Temperature, VCC, RX power, TX Bias	00 00 0F DE	
196-211	16	Vendor SN	Serial number provided by vendor	Programmed by Factory	
212-219	8	Date Code	Year,Month,Day	Programmed by Factory	
220	1	Diagnostic Monitoring Type	Indicates which types of diagnostic monitoring are implemented (if any) in the Module. Bit 1,0 Reserved	08	
221	1	Enhanced options	Indicates which optional enhanced features are implemented in the Module.	00	
222	1	Reserved	Reserved	-	
223	1	CC EXT	Check code for the Extended ID Fields (addresses 192-222)	-	
224-255	32	Vendor Specific	Vendor Specific EEPROM	-	
Upper Memory Map Page 02h					
IIC 地址	数据长度	寄存器名称	描述	取值 (HEX)	备注
128-255	128	Upper Memory Map	User Code Area	-	

注:

1. 写入密码区缺省为 FFFFFFFF，读出为最后的写入值
2. 模块 A0H 的表 00、表 02 带有写保护功能，进入安全等级 1 可写

SFP 端

Address A0					
IIC 地址	数据长度	寄存器名称	描述	取值 (HEX)	备注
0	1	Identifier	SFP or SFP+	03	
1	1	Ext. Identifier	GBIC/SFP function is defined by two-wire interface ID only	04	
2	1	Connector	Copper pigtail	21	
3-10	8	Transceiver	Active Cable	00 00 00 00 00 00 08 00	
11	1	Encoding	64B/66B	06	
12	1	BR, Nominal	Nominal Bit Rate 10.3Gb/s	67	

13	1	Rate Identifier	Type of rate select functionality	00	
14	1	Length(SMF,km)	Link length supported for single mode fiber, units of km	00	
15	1	Length (SMF)	Link length supported for single mode fiber, units of 100 m	00	
16	1	Length (50um)	Link length supported for 50 um OM2 fiber, units of 10 m	00	
17	1	Length (62.5um)	Link length supported for 62.5 um OM1 fiber, units of 10 m	00	
18	1	Length (OM4 or copper cable)	Link length supported for 50um OM4 fiber, units of 10m. Alternatively copper or direct attach cable, units of m	-	
19	1	Length (OM3)	Link length supported for 50 um OM3 fiber, units of 10 m	00	
20-35	16	Vendor name	MODULETEK	4D 4F 44 55 4C 45 54 45 4B 20 20 20 20 20 20 20	
36	1	Transceiver	Code for electronic or optical compatibility	0D	
37-39	3	Vendor OUI	SFP vendor IEEE company ID	00 00 00	
40-55	16	Vendor PN	Part number in Order information	-	
56-59	4	Vendor rev	Revision level for part number provided by vendor (ASCII)	-	
60-61	2	Wavelength	Laser wavelength (Passive/ Active Cable Specification Compliance)	00 00	
62	1	Unallocated		00	
63	1	CC BASE	Check code for Base ID Fields (addresses 0 to 62)	-	
64-65	2	Options	Indicates which optional transceiver signals are implemented	00 00	
66	1	BR, max	Upper bit rate margin	64	
67	1	BR, min	Lower bit rate margin	00	
68-83	16	Vendor SN	Serial number provided by vendor	Programmed by Factory	
84-91	8	Date code	Year,Month,Day	Programmed by Factory	

92	1	Diagnostic Monitoring Type	Indicates which type of diagnostic monitoring is implemented (if any) in the transceiver	00	
93	1	Enhanced Options	Indicates which optional enhanced features are implemented (if any) in the transceiver	00	
94	1	SFF-8472 Compliance	Indicates which revision of SFF-8472 the transceiver complies with.	00	
95	1	CC EXT	Check code for the Extended ID Fields (addresses 64 to 94)	-	
96-127	32	Vendor Specific	Vendor Specific EEPROM	-	
128-255	128	Vendor Specific	Vendor Specific EEPROM	-	
Address A2 Low					
IIC 地址	数据长度	寄存器名称	描述	取值 (HEX)	备注
0-1	2	Temp High Alarm	75°C	4B 00	
2-3	2	Temp Low Alarm	-5°C	FB 00	
4-5	2	Temp High Warning	70°C	46 00	
6-7	2	Temp Low Warning	0°C	00 00	
8-9	2	Vcc High Alarm	3.9V	98 58	
10-11	2	Vcc Low Alarm	2.7V	69 78	
12-13	2	Vcc High Warning	3.7V	90 88	
14-15	2	Vcc Low Warning	2.9V	71 48	
16-17	2	Bias High Alarm	Bias High Alarm	00 00	
18-19	2	Bias Low Alarm	Bias Low Alarm	00 00	
20-21	2	Bias High Warning	Bias High Warning	00 00	
22-23	2	Bias Low Warning	Bias Low Warning	00 00	
24-25	2	TxPower High Alarm	TxPower High Alarm	00 00	
26-27	2	TxPower Low Alarm	TxPower Low Alarm	00 00	
28-29	2	TxPower High Warning	TxPower High Warning	00 00	
30-31	2	TxPower Low Warning	TxPower Low Warning	00 00	
32-33	2	RxPower High Alarm	RxPower High Alarm	00 00	
34-35	2	RxPower Low Alarm	RxPower Low Alarm	00 00	
36-37	2	RxPower High Warning	RxPower High Warning	00 00	

38-39	2	RxPower Low Warning	RxPower Low Warning	00 00	
40-55	16	Reserved	Reserved	00	
56-59	4	Ext RxPwr 4	Ext RxPwr 4	00 00 00 00	
60-63	4	Ext RxPwr 3	Ext RxPwr 3	00 00 00 00	
64-67	4	Ext RxPwr 2	Ext RxPwr 2	00 00 00 00	
68-71	4	Ext RxPwr 1	Ext RxPwr 1	00 00 00 00	
72-75	4	Ext RxPwr 0	Ext RxPwr 0	00 00 00 00	
76-77	2	Ext Bias Slope	Ext Bias Slope	00 00	
78-79	2	Ext Bias Offset	Ext Bias Offset	00 00	
80-81	2	Ext TxPower Slope	Ext TxPower Slope	00 00	
82-83	2	Ext TxPower Offset	Ext TxPower Offset	00 00	
84-85	2	Ext Temp Slope	Ext Temp Slope	01 00	
86-87	2	Ext Temp Offset	Ext Temp Offset	00 00	
88-89	2	Ext Vcc Slope	Ext Vcc Slope	01 00	
90-91	2	Ext Vcc Offset	Ext Vcc Offset	00 00	
92-94	3	Reserved	Reserved	00	
95	1	Checksum	0-94 Byte Checksum	30	
96-97	2	Temperature	Temperature	-	
98-99	2	Vcc	Vcc	-	
100-101	2	Bias Current	Bias Current	00 00	
102-103	2	Tx Power	Tx Power	00 00	
104-105	2	Rx Power	Rx Power	00 00	
106-109	4	Reserved	Reserved	00 00 00 00	
110	1	Optional Status/ Control Bits	02		
111	1	Reserved	Reserved	00	
112-113	2	Alarm Flags	Alarm Flags	00 00	
114-115	2	Reserved	Reserved	00 00	
116-117	2	Warning Flags	Warning Flags	00 00	
118-121	4	Reserved	Reserved	00 00 00 00	
122	1	Security Level	Security Level: 00=Normal Mode; 01=User Mode (Level 1); 02=Factory Mode (Level 2);	00	
123-126	4	Password Entry	Password Entry Area	00 00 00 00	
127	1	Table Selection	Page Select Byte	00	

Address A2 Page 00h/01h					
IIC 地址	数据长度	寄存器名称	描述	取值 (HEX)	备注
128-255	128	Upper Memory Map	User Code Area	-	

注:

1. 写入密码区缺省为 00000000, 读出为最后的写入值
2. 模块的 A0H 和 A2H 的表 00 带有写保护功能, 进入安全等级 1 可写

用户模式

模块	安全等级 1 缺省密码	密码是否可改	权限
QSFP 端	00 00 10 11	否	1、可读写 A0 T00/T02
SFP 端	00 00 00 00	否	1、可读 A0
			2、可读 A2 T00

注:

1. 寄存器详情见标准定义表格。

线缆规格

参数	符号	最小值	典型值	最大值	单位	备注
线规		30		28	AWG	
线缆阻抗	Z	90	100	110	Ohm	

框图

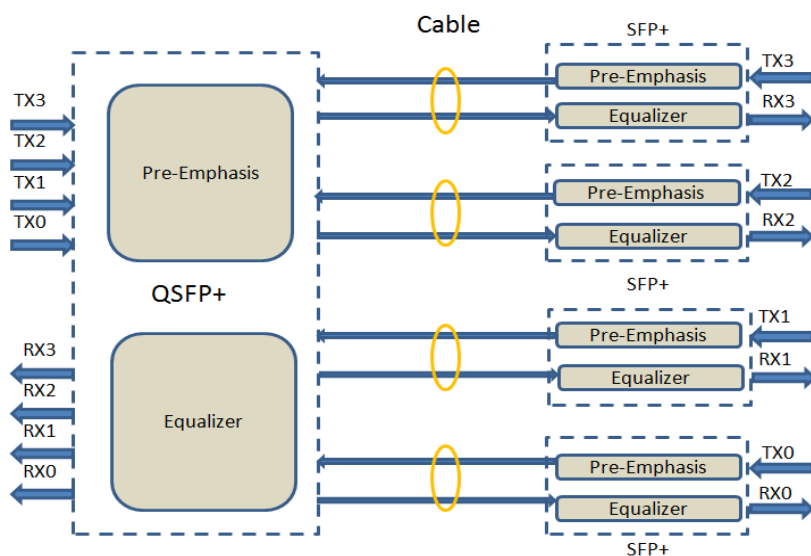

产品重量

参数	符号	典型值	单位	备注
30AWG 产品重量	G_{D30}	245	g/PCS	1
28AWG 产品重量	G_{D28}	310	g/PCS	1
30AWG 电缆重量	G_{C30}	110	g/M	2
28AWG 电缆重量	G_{C28}	170	g/M	2
SFP 端防尘帽重量	G_S	0.80	g/个	
QSFP 端防尘帽重量	G_Q	1.40	g/个	

注:

1. DAC-QSFP-4SFP-40G-A-xxAWG-1M-D0C0B 产品的重量
2. 单位长度电缆重量 (4 根)。例如: DAC-QSFP-4SFP-40G-A-28AWG-10M-D0C0B 产品的重量为:
 $310+170*(10-1)+0.80*4+1.40=1844.6g$

外形尺寸

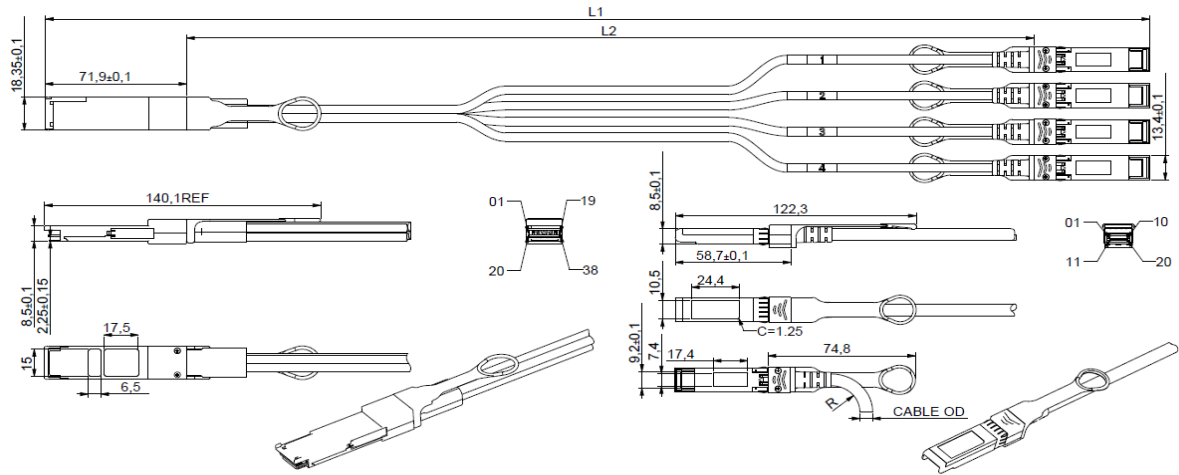

未注尺寸公差 $\pm 0.2\text{mm}$
单位：毫米

标称长度

序号	模块标称长度 L1 (厘米)	公差范围 (厘米)
1	100	2
2	200	2
3	300	4
4	500	6
5	600	6
6	700	8
7	1000	8

QSFP 引脚图

顶部视图

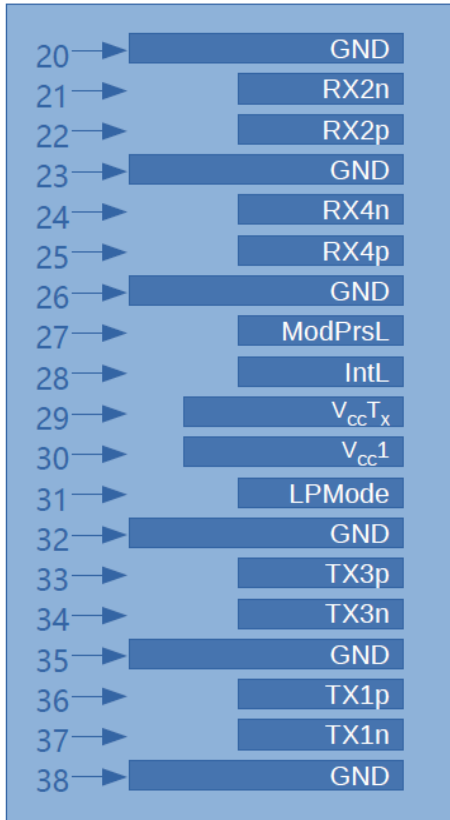

底部视图

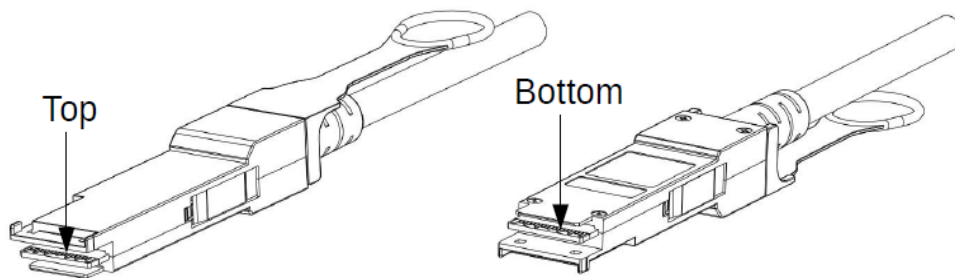
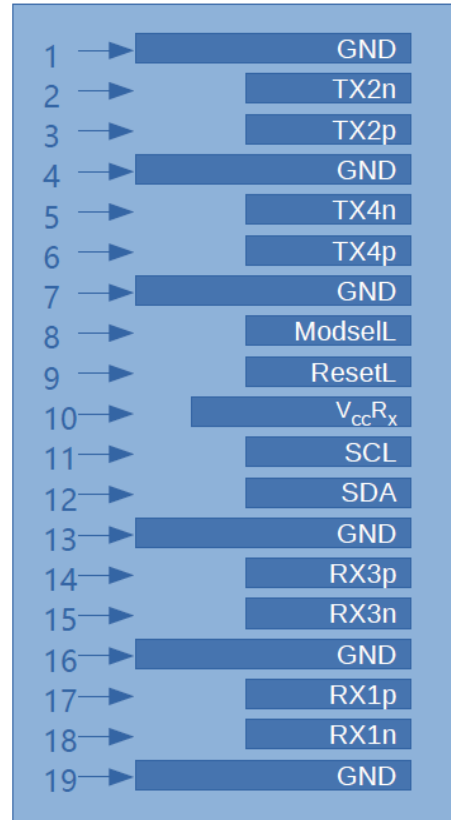

SFP 引脚图

顶部视图

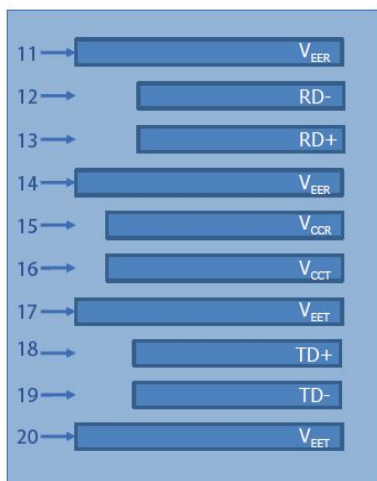

底部视图

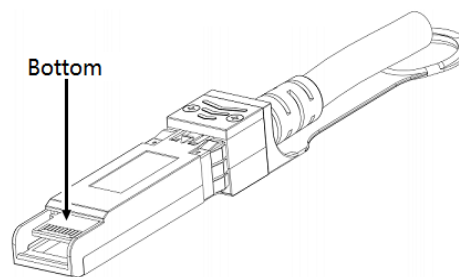
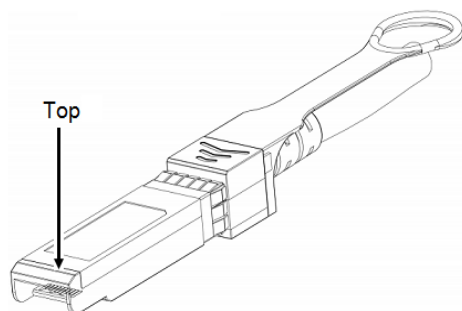
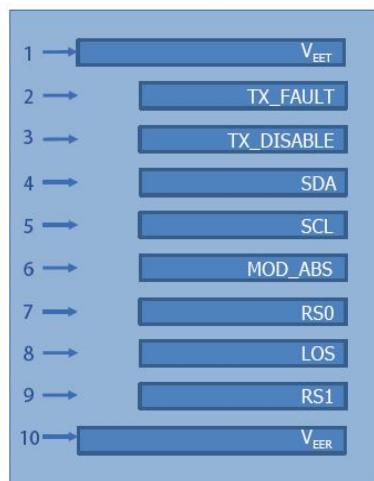

QSFP 引脚定义

PIN #	符号	说明	备注
1	GND	地	5
2	TX2n	发射端数据输入负, LAN2	
3	TX2p	发射端数据输入正, LAN2	
4	GND	地	5
5	TX4n	发射端数据输入负, LAN4	
6	TX4p	发射端数据输入正, LAN4	
7	GND	地	5
8	ModSelL	模块选择引脚, 低电平时模块响应两线串口通信	1
9	ResetL	模块重置	2
10	V _{CC} R _X	+3.3V 接收端电源供电	
11	SCL	两线串行接口时钟线	
12	SDA	两线串行接口数据线	
13	GND	地	5
14	RX3P	接收端数据输出正, LAN3	
15	RX3n	接收端数据输出负, LAN3	
16	GND	地	5
17	RX1P	接收端数据输出正, LAN1	
18	RX1n	接收端数据输出负, LAN1	
19	GND	地	5
20	GND	地	5
21	Rx2n	接收端数据输出负, LAN2	
22	Rx2p	接收端数据输出正, LAN2	
23	GND	地	5
24	Rx4n	接收端数据输出负, LAN4	
25	Rx4p	接收端数据输出正, LAN4	
26	GND	地	5
27	ModPrsL	模块插入指示引脚, 在模块内接地	3
28	IntL	中断	4
29	V _{CC} T _X	+3.3V 发射端电源供电	
30	V _{CC} 1	+3.3V 电源	
31	LPMoDe	低功耗模式	5
32	GND	地	5
33	Tx3p	发射端数据输入正, LAN3	

34	Tx3n	发射端数据输入负, LAN3	
35	GND	地	5
36	Tx1p	发射端数据输入正, LAN1	
37	Tx1n	发射端数据输入负, LAN1	
38	GND	地	5

注:

1. ModSelL 是输入引脚。当它通过主机保持低电平时, 模块响应 2 线串行通信命令。ModSelL 允许在单个 2 线接口总线上使用多个 QSFP 模块。如果 ModSelL 为“高”, 模块将不响应来自主机的任何 2 线接口通信。ModSelL 在模块中具有内部上拉电阻。
2. 模块重启引脚, 当 ResetL 引脚上低电平持续时间长于最小脉冲长度时会使模块复位, 并将所有用户模块恢复为它们的默认状态, 在执行复位器件, 主机应忽略所有状态位, 直到模块复位中断完成。
3. 该引脚高电平有效, 表示模块在低功耗模式下运行, 该信号对本产品功能无影响。
4. IntL 是输出引脚, 是开路集电极输出, 应在主机板上以 4.7kΩ-10kΩ 电阻上拉到 Vcc。当它是低电平时, 表示模块可能操作故障。主机使用 2 线串行接口识别中断源。
5. 电路接地与外壳接地内部隔离。

SFP 引脚定义

PIN #	符号	说明	备注
1	V _{EET}	发射端地 (与接收端地共用)	1
2	TX_FAULT	发射端故障告警, 未使用	
3	TX_DISABLE	该信号在高电平或开路时关闭模块发射端, 未使用	
4	SDA	两线串行接口数据线	2
5	SCL	两线串行接口时钟线	2
6	MOD_ABS	模块插入指示引脚, 在模块内接地	2
7	RS0	未连接	
8	LOS	信号丢失指示, 低电平表示模块正常工作, 内部接地	
9	RS1	未连接	
10	V _{EER}	接收端地 (与发射端地共用)	1
11	V _{EER}	接收端地 (与发射端地共用)	1
12	RD-	接收端数据输出负, 交流耦合	
13	RD+	接收端数据输出正, 交流耦合	
14	V _{EER}	接收端地 (与发射端地共用)	1
15	V _{CCR}	接收端电源	
16	V _{CCT}	发射端电源	
17	V _{EET}	发射端地 (与接收端地共用)	1
18	TD+	发射端数据输入正, 交流耦合	
19	TD-	发射端数据输入负, 交流耦合	
20	V _{EET}	发射端地 (与接收端地共用)	1

注:

1. 电路地与模块外壳是绝缘的。
2. 应在主机板上以 4.7kΩ-10kΩ 的电阻上拉到 2V 至 3.6V 之间的电压。

参考文献

1. IEEE standard 802.3ae. IEEE Standard Department, 2008.