

数据手册

MODULETEK: DAC-SFP-10G-A-xxAWG-aa.aaM-C0C0B

SFP 10G 有源线缆

产品简介

ModuleTek 的 10G 有源线缆使用屏蔽的高速差分线缆，内部具备预加重、均衡等高速电信号补偿功能，可以增加无补偿功能交换机之间的数据传输距离。该产品符合万兆以太网标准和 SFP 多源协议 (MSA) 标准，支持 10G 传输速率，也可以向下兼容低速率应用，其最大的特点是使用的线缆更细，传输的距离更长，低功耗，低成本和高可靠性，是 10G 速率短距离应用的优选方案，普遍应用于数据中心同机柜或相邻机柜之间的数据传输。

产品特性

- 高达 10Gb/s 的双向数据传输能力
- 提供 24AWG 至 30AWG 线缆
- 双 SFP 连接器
- 工业标准小型可插拔 (SFP) 封装
- 跨度达 15 米
- 热插拔设计
- 单电源供电 3.3V
- 符合 RoHS 标准
- 工作温度范围 (外壳温度) :
商业温度等级: 0°C 至 70°C



应用

10G 以太网

10G 光纤通道

订购信息

型号	产品 ID	描述	线规	长度
DAC-SFP-10G-A-30AWG-aa.aaM-C0C0B	M398701	SFP 10G 有源线缆, aa.aa \leq 7	30AWG	\leq 7 米
DAC-SFP-10G-A-28AWG-aa.aaM-C0C0B	M450901	SFP 10G 有源线缆, aa.aa \leq 10	28AWG	\leq 10 米
DAC-SFP-10G-A-24AWG-aa.aaM-C0C0B	M019801	SFP 10G 有源线缆, aa.aa \leq 15	24AWG	\leq 15 米
注: 1. "A" 表示有源线缆 2. "aa.aa" 表示以米为单位的线缆长度 3. 该产品可实现写保护功能 4. 上表中产品的线径是不同长度下的默认值, 我们还可以为有特殊要求的客户提供其他线径产品 5. 产品 ID 为我司产品标准型号的简写订货号				
如需了解更多信息或订购上述产品, 请联系: 电子邮件: sales@moduletek.com 摩泰光电官网: www.moduletek.com				

产品一般规格

参数	符号	最小值	典型值	最大值	单位	备注
数据速率	DR		10.3125		Gb/s	1
误码率	BER			10^{-12}		
工作温度	T _C	0		70	°C	2
储存温度	T _{STO}	-40		85	°C	3
工作电压	V _{CC}	3.14	3.30	3.46	V	4
工作电流	I _{CC}		100	300	mA	4

注:

1. IEEE 802.3ae 兼容
2. 外壳表面温度
3. 环境温度
4. 电接口

标准定义表格

Address A0					
IIC 地址	数据长度	寄存器名称	描述	取值 (HEX)	备注
0	1	Identifier	SFP or SFP+	03	
1	1	Ext. Identifier	GBIC/SFP function is defined by two-wire interface ID only	04	
2	1	Connector	Copper pigtail	21	
3-10	8	Transceiver	Active Cable	00 00 00 00 00 00 08 00	
11	1	Encoding	Code for high speed serial encoding algorithm	00	
12	1	BR, Nominal	Nominal Bit Rate 10.3Gb/s	67	
13	1	Rate Identifier	Type of rate select functionality	00	
14	1	Length(SMF,km)	Link length supported for single mode fiber, units of km	00	
15	1	Length (SMF)	Link length supported for single mode fiber, units of 100 m	00	
16	1	Length (50um)	Link length supported for 50 um OM2 fiber, units of 10 m	00	
17	1	Length (62.5um)	Link length supported for 62.5 um OM1 fiber, units of 10 m	00	
18	1	Length (OM4 or copper cable)	Link length supported for 50um OM4 fiber, units of 10m. Alternatively copper or direct attach cable, units of m	-	
19	1	Length (OM3)	Link length supported for 50 um OM3 fiber, units of 10 m	00	
20-35	16	Vendor name	MODULETEK	4D 4F 44 55 4C 45 54 45 4B 20 20 20 20 20 20 20	
36	1	Transceiver	Code for electro nic or optical compatibility	0D	
37-39	3	Vendor OUI	SFP vendor IEEE company ID	00 00 00	
40-55	16	Vendor PN	Part number in Order information	-	

56-59	4	Vendor rev	Revision level for part number provided by vendor (ASCII)	-	
60-61	2	Wavelength	Laser wavelength (Passive/Active Cable Specification Compliance)	00 00	
62	1	Unallocated		00	
63	1	CC BASE	Check code for Base ID Fields (addresses 0 to 62)	-	
64-65	2	Options	Indicates which optional transceiver signals are implemented	00 00	
66	1	BR, max	Upper bit rate margin	64	
67	1	BR, min	Lower bit rate margin	00	
68-83	16	Vendor SN	Serial number provided by vendor	Programmed by Factory	
84-91	8	Date code	Year,Month,Day	Programmed by Factory	
92	1	Diagnostic Monitoring Type	Indicates which type of diagnostic monitoring is implemented (if any) in the transceiver	00	
93	1	Enhanced Options	Indicates which optional enhanced features are implemented (if any) in the transceiver	00	
94	1	SFF-8472 Compliance	Indicates which revision of SFF-8472 the transceiver complies with.	00	
95	1	CC EXT	Check code for the Extended ID Fields (addresses 64 to 94)	-	
96-127	32	Vendor Specific	Vendor Specific EEPROM	-	
128-255	128	Vendor Specific	Vendor Specific EEPROM	-	
Address A2 Low					
IIC 地址	数据长度	寄存器名称	描述	取值 (HEX)	备注
0-1	2	Temp High Alarm	75°C	4B 00	
2-3	2	Temp Low Alarm	-5°C	FB 00	
4-5	2	Temp High Warning	70°C	46 00	
6-7	2	Temp Low Warning	0°C	00 00	
8-9	2	Vcc High Alarm	3.9V	98 58	
10-11	2	Vcc Low Alarm	2.7V	69 78	

12-13	2	Vcc High Warning	3.7V	90 88	
14-15	2	Vcc Low Warning	2.9V	71 48	
16-17	2	Bias High Alarm	Bias High Alarm	00 00	
18-19	2	Bias Low Alarm	Bias Low Alarm	00 00	
20-21	2	Bias High Warning	Bias High Warning	00 00	
22-23	2	Bias Low Warning	Bias Low Warning	00 00	
24-25	2	TxPower High Alarm	TxPower High Alarm	00 00	
26-27	2	TxPower Low Alarm	TxPower Low Alarm	00 00	
28-29	2	TxPower High Warning	TxPower High Warning	00 00	
30-31	2	TxPower Low Warning	TxPower Low Warning	00 00	
32-33	2	RxPower High Alarm	RxPower High Alarm	00 00	
34-35	2	RxPower Low Alarm	RxPower Low Alarm	00 00	
36-37	2	RxPower High Warning	RxPower High Warning	00 00	
38-39	2	RxPower Low Warning	RxPower Low Warning	00 00	
40-55	16	Reserved	Reserved	00	
56-59	4	Ext RxPwr 4	Ext RxPwr 4	00 00 00 00	
60-63	4	Ext RxPwr 3	Ext RxPwr 3	00 00 00 00	
64-67	4	Ext RxPwr 2	Ext RxPwr 2	00 00 00 00	
68-71	4	Ext RxPwr 1	Ext RxPwr 1	00 00 00 00	
72-75	4	Ext RxPwr 0	Ext RxPwr 0	00 00 00 00	
76-77	2	Ext Bias Slope	Ext Bias Slope	00 00	
78-79	2	Ext Bias Offset	Ext Bias Offset	00 00	
80-81	2	Ext TxPower Slope	Ext TxPower Slope	00 00	
82-83	2	Ext TxPower Offset	Ext TxPower Offset	00 00	
84-85	2	Ext Temp Slope	Ext Temp Slope	01 00	
86-87	2	Ext Temp Offset	Ext Temp Offset	00 00	
88-89	2	Ext Vcc Slope	Ext Vcc Slope	01 00	
90-91	2	Ext Vcc Offset	Ext Vcc Offset	00 00	
92-94	3	Reserved	Reserved	00	
95	1	Checksum	0-94 Byte Checksum	30	
96-97	2	Temperature	Temperature	-	
98-99	2	Vcc	Vcc	-	

100-101	2	Bias Current	Bias Current	00 00	
102-103	2	Tx Power	Tx Power	00 00	
104-105	2	Rx Power	Rx Power	00 00	
106-109	4	Reserved	Reserved	00 00 00 00	
110	1	Optional Status/ Control Bits	00		
111	1	Reserved	Reserved	00	
112-113	2	Alarm Flags	Alarm Flags	00 00	
114-115	2	Reserved	Reserved	00 00	
116-117	2	Warning Flags	Warning Flags	00 00	
118-121	4	Reserved	Reserved	00 00 00 00	
122	1	Security Level	Security Level: 00=Normal Mode; 01=User Mode (Level 1); 02=Factory Mode (Level 2);	00	
123-126	4	Password Entry	Password Entry Area	00 00 00 00	
127	1	Table Selection	Page Select Byte	00	
Address A2 Page 00h/01h					
IIC 地址	数据 长度	寄存器名称	描述	取值 (HEX)	备注
128-255	128	Upper Memory Map	User Code Area	-	

注:

1. 写密码区缺省为 00000000，读出为最后的写入值
2. 模块的 A0H 和 A2H 的表 00、表 01 带有写保护功能

用户模式

安全等级 1 缺省密码	密码是否可改	权限
00 00 00 00	否	1、可读 A0
		2、可读 A2 T00

注:

1. 寄存器详情见标准定义表格。

框图

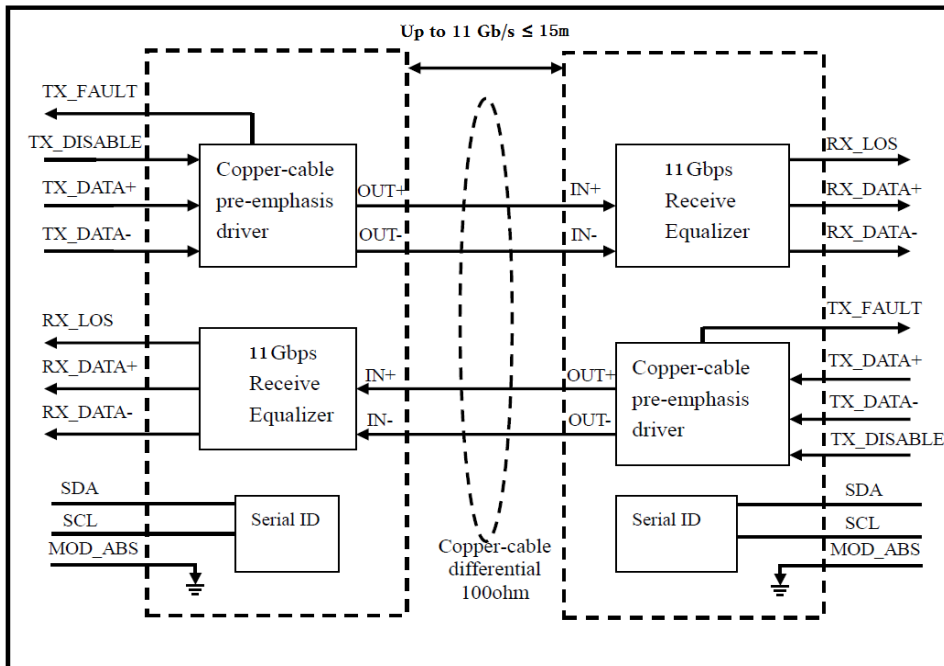

产品重量

参数	符号	典型值	单位	备注
30AWG 产品重量	G _{D30}	72	g/PCS	1
28AWG 产品重量	G _{D28}	88	g/PCS	1
24AWG 产品重量	G _{D26}	96	g/PCS	1
30AWG 电缆重量	G _{C30}	26	g/M	
28AWG 电缆重量	G _{C28}	42	g/M	
24AWG 电缆重量	G _{C26}	50	g/M	
防尘帽重量	G _S	0.80	g/个	

注:

1. DAC-SFP-10G-A-xxAWG-1M-C0C0B 产品的重量。例如: DAC-SFP-10G-A-28AWG-10M-C0C0B 的重量为: $88+42*(10-1)+0.80*2=467.6g$

线缆规格

参数	符号	最小值	典型值	最大值	单位	备注
线规		30		24	AWG	
线缆阻抗	Z	90	100	110	Ohm	

外形尺寸

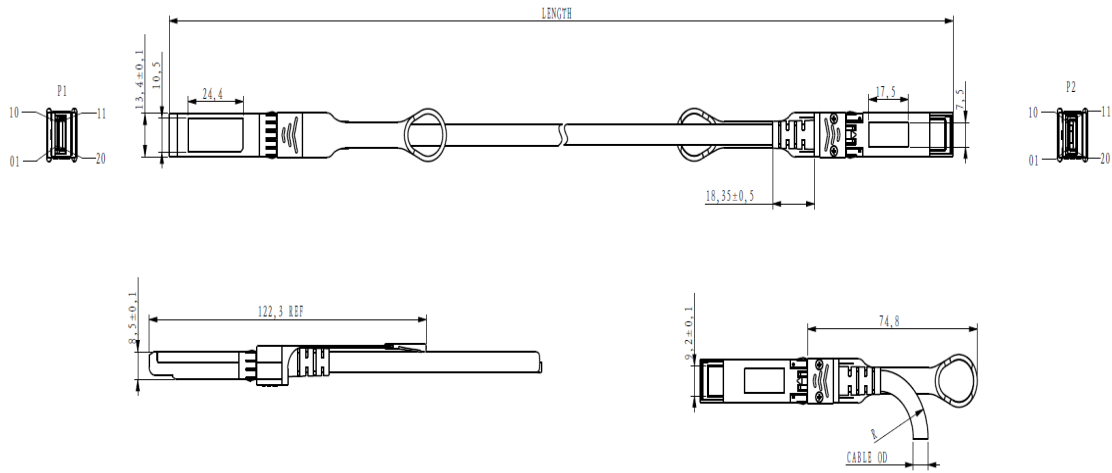

未注尺寸公差 ±0.2mm
单位：毫米

长度公差

序号	标称长度 L(米)	公差范围 ±(厘米)
1	Length ≤ 2	2
2	2 < Length ≤ 4	4
3	4 < Length ≤ 6	6
4	6 < Length	8

SFP 引脚图

顶部视图

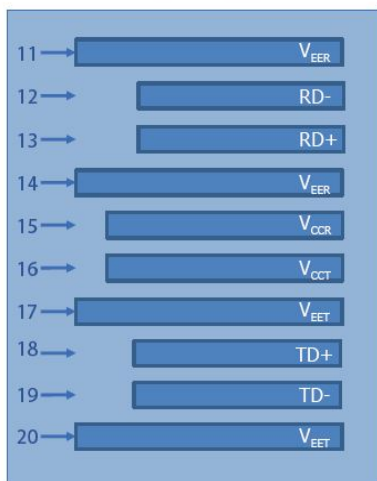

底部视图

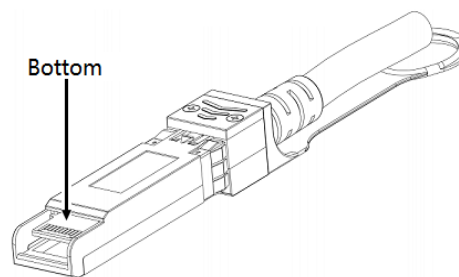
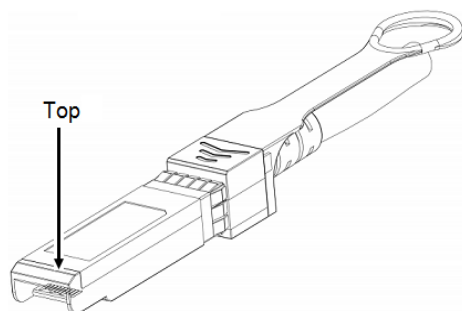
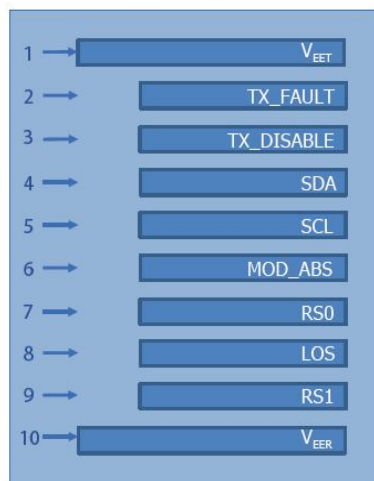

引脚定义

PIN #	符号	说明	备注
1	V _{EET}	发射端地 (与接收端地共用)	1
2	TX_FAULT	发射端故障告警	
3	TX_DISABLE	该信号在高电平或开路时关闭模块发射端	2
4	SDA	两线串行接口数据线	3
5	SCL	两线串行接口时钟线	3
6	MOD_ABS	模块插入指示引脚, 在模块内接地	3
7	RS0	未连接	
8	LOS	信号丢失指示, 低电平表示模块正常工作	4
9	RS1	未连接	
10	V _{EER}	接收端地 (与发射端地共用)	1
11	V _{EER}	接收端地 (与发射端地共用)	1
12	RD-	接收端数据输出负, 交流耦合	
13	RD+	接收端数据输出正, 交流耦合	
14	V _{EER}	接收端地 (与发射端地共用)	1
15	V _{CCR}	接收端电源	
16	V _{CCT}	发射端电源	
17	V _{EET}	发射端地 (与接收端地共用)	1
18	TD+	发射端数据输入正, 交流耦合	
19	TD-	发射端数据输入负, 交流耦合	
20	V _{EET}	发射端地 (与接收端地共用)	1

注:

1. 电路地与模块外壳是绝缘的
2. 禁用: T_{DIS} > 2V 或开路, 使能: T_{DIS} < 0.8V
3. 应在主机板上以 4.7kΩ-10kΩ 的电阻上拉到 2V 至 3.6V 之间的电压
4. LOS 是集电极开路输出

参考文献

1. IEEE standard 802.3ae. IEEE Standard Department, 2005.