

DATA SHEET

MODULETEK: SFP-GE-CWDM-xxxx-26DB-C10

1.25Gb/s SFP (Small Form Pluggable) CWDM (1470nm - 1610nm) Transceiver

SFP-GE-CWDM-xxxx-26DB-C10 Overview

ModuleTek's SFP-GE-CWDM-xxxx-26DB-C10 SFP optical transceivers are designed for Gigabit Ethernet and Fibre Channel network equipment, they are available in 8 different CWDM wavelengths, from 1470nm to 1610nm. The product implements digital diagnostics via a 2-wire serial bus, compliant with the INF-8074i Small Form Factor Pluggable Multi-Source Agreement (MSA) and SFF-8472 standard.

Product Features

- Up to 1.25 Gb/s bi-directional data links
- Compliant with IEEE 802.3z Gigabit Ethernet standard
- Compliant with Fiber Channel 100-SM-LL-V standard
- Industry standard small form pluggable (SFP) package
- Compliant with SFP MSA
- Hot-pluggable SFP footprint
- Uncooled DFB laser transmitter in 8 possible CWDM wavelengths
- Receiver with PIN
- Duplex LC connector
- Built-in digital diagnostic functions
- Up to 80km on 9/125um SMF
- Single power supply 3.3V
- RoHS Compliant
- Class 1 laser product complies with EN 60825-1
- Operating temperature range: 0°C to 70°C

Applications

- 1.25Gb/s Gigabit Ethernet
- 1.063Gb/s Fiber Channel

Ordering Information

Part Number	Description	Color on Clasp
SFP-GE-CWDM-1470-26DB-C10	GE/FC SFP CWDM 1470nm SMF 80km with DOM function	Gray
SFP-GE-CWDM-1490-26DB-C10	GE/FC SFP CWDM 1490nm SMF 80km with DOM function	Violet
SFP-GE-CWDM-1510-26DB-C10	GE/FC SFP CWDM 1510nm SMF 80km with DOM function	Blue
SFP-GE-CWDM-1530-26DB-C10	GE/FC SFP CWDM 1530nm SMF 80km with DOM function	Green
SFP-GE-CWDM-1550-26DB-C10	GE/FC SFP CWDM 1550nm SMF 80km with DOM function	Yellow
SFP-GE-CWDM-1570-26DB-C10	GE/FC SFP CWDM 1570nm SMF 80km with DOM function	Orange
SFP-GE-CWDM-1590-26DB-C10	GE/FC SFP CWDM 1590nm SMF 80km with DOM function	Red
SFP-GE-CWDM-1610-26DB-C10	GE/FC SFP CWDM 1610nm SMF 80km with DOM function	Brown
For More Information: ModuleTek Limited Web: www.moduletek.com Email: sales@moduletek.com		

General Specifications

Parameter	Symbol	Min	Typ	Max	Unit	Remarks
Data Rate	DR	0.622		1.25	Gb/s	
Bit Error Rate	BER			10^{-12}		
Operating Temperature	T _C	0		70	°C	1
Storage Temperature	T _{STO}	-40		85	°C	2
Supply Current	I _{CC}		200	300	mA	3
Input Voltage	V _{CC}	3.14	3.3	3.46	V	
Maximum Voltage	V _{MAX}	-0.5		4	V	3

Notes:

1. Case temperature
2. Ambient temperature
3. For electrical power interface

Optical – Characteristics – Transmitter

$V_{CC}=3.14V$ to $3.46V$, $T_C=0^{\circ}C$ to $70^{\circ}C$

Parameter	Symbol	Min	Typ	Max	Unit	Remarks
Output Optical Power	P_{TX}	0		5	dBm	1
Optical Center Wavelength –1470nm	λ_C	1465	1471	1477	nm	
Optical Center Wavelength –1490nm		1485	1491	1497	nm	
Optical Center Wavelength –1510nm		1505	1511	1517	nm	
Optical Center Wavelength –1530nm		1525	1531	1537	nm	
Optical Center Wavelength –1550nm		1545	1551	1557	nm	
Optical Center Wavelength –1570nm		1565	1571	1577	nm	
Optical Center Wavelength –1590nm		1585	1591	1597	nm	
Optical Center Wavelength –1610nm		1605	1611	1617	nm	
Wavelength Temperature Dependence				0.08	0.125	nm/ $^{\circ}C$
Extinction Ratio	ER	9			dB	
Side Mode Suppression Ratio	SMSR	30			dB	
Spectral Width (-20dB)	$\Delta\lambda$			1	nm	
Optical Rise/Fall Time (20%-80%)	t_r / t_f			180	ps	
Relative Intensity Noise	RIN			-120	dB/Hz	
Transmitter Jitter (peak to peak)	TJ			100	ps	
Output Eye	Compliant with IEEE 802.3z					

Notes:

1. Class 1 Product

Optical – Characteristics – Receiver

$V_{CC}=3.14V$ to $3.46V$, $T_C=0^{\circ}C$ to $70^{\circ}C$

Parameter	Symbol	Min	Typ	Max	Unit	Remarks
Receiver Overload	P_{OL}	0			dBm	
Optical Center Wavelength	λ_C	1260		1620	nm	
Receiver Sensitivity @ 1.25Gb/s	R_{X_SEN}			-26	dBm	1
LOS Assert	LOS_A	-35			dBm	
LOS De-Assert	LOS_D			-26	dBm	
LOS Hysteresis	LOS_H		1		dB	

Notes:

1. Measured with a 2⁷-1 test pattern,@1.25Gb/s,BER<10⁻¹²

Electrical – Characteristics – Transmitter

$V_{CC}=3.14V$ to $3.46V$, $T_C=0^{\circ}C$ to $70^{\circ}C$

Parameter	Symbol	Min	Typ	Max	Unit	Remarks
Input differential impedance	R_{IN}		100		Ω	
Single ended data input swing	V_{IN_PP}	250		1200	mV	
Transmit disable voltage	V_D	$V_{CC}-1.3$		V_{CC}	V	
Transmit enable voltage	V_{EN}	V_{EE}		$V_{EE}+0.8$	V	
Transmit disable assert time				10	μs	

Electrical – Characteristics – Receiver

$V_{CC}=3.14V$ to $3.46V$, $T_C=0^{\circ}C$ to $70^{\circ}C$

Parameter	Symbol	Min	Typ	Max	Unit	Remarks
Single ended data output swing	V_{OUT_PP}	250		800	mV	
Data output rise/fall time (20%-80%)	t_r/t_f		100	175	ps	
LOS Assert	V_{LOS_A}	$V_{CC}-0.5$		V_{CC_HOST}	V	
LOS De-Assert	V_{LOS_D}	V_{EE}		$V_{EE}+0.5$	V	

Digital Diagnostic Functions

SFP-GE-CWDM-xxxx-26DB-C10 supports the 2-wire serial communication protocol as defined in SFP MSA. Digital diagnostic information is accessible over the 2-wire interface at the address 0xA2. Digital diagnostics for SFP-GE-CWDM-xxxx-26DB-C10 are internally calibrated by default. The internal micro control unit accesses the device operating parameters in real time, Such as transceiver temperature, laser bias current, transmitted optical power, received optical power and transceiver supply voltage. The module implements the alarm function of the SFP MSA, alerts the user when a particular operating parameter exceeds the factory-set normal range.

Parameter	Symbol	Accuracy	Units	Report Range		Unit	Remarks
Internal Calibration							
Temperature	Temp	± 3	$^{\circ}C$	-40	95	$^{\circ}C$	
Voltage	V_{CC}	± 0.1	V	2.7	3.9	V	
Bias Current	Ibias	± 10	%	1	80	mA	
Tx Power	P_{TX}	± 3	dB	-5	5	dBm	
Rx Power	P_{RX}	± 3	dB	-25	5	dBm	

Block-Diagram-of-Transceiver

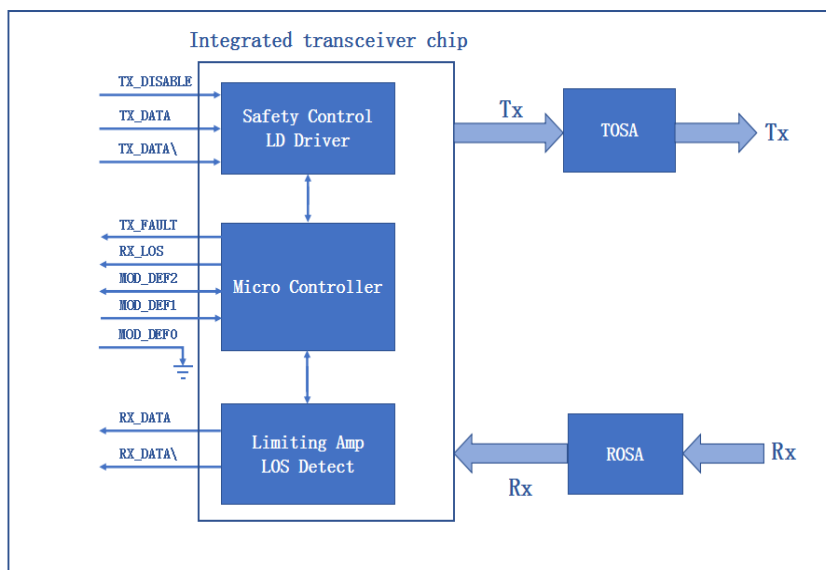

Functions Description

The transmitter is mainly composed of a laser driver part of the intelligent transceiver chip and a TOSA (light-emitting component). The TOSA includes a DFB laser and a backlight photodetection chip. When the module is working, the input signal is connected to the intelligent transceiver chip, at this time, the laser driver of the intelligent transceiver chip supplies the bias current and the modulation current to the laser. The intelligent transceiver chip simultaneously uses an automatic optical power control (APC) feedback loop to maintain a constant average optical power of the laser output. The purpose is to eliminate the change of the output optical signal due to temperature changes and aging of the light source device. When the transmitter enable pin (TX_Disable) is high (TTL logic "1"), the laser output is turned off. When TX_Disable is low (TTL logic "0"), the laser will turn on within 1ms. When the transmitter fault signal (TX_Fault) is reported as high, indicates a transmitter failure caused by the transmitter's bias current or transmitted optical power or laser tube temperature exceeding a preset alarm threshold. Low indicates normal operation.

The receiver is mainly composed of a limiting amplifier part of the intelligent transceiver chip and a ROSA (light-receiving component). The ROSA includes a PIN photodetector and a transimpedance amplifier chip. When the ROSA detects the incident light signal, it will be converted into a photo-generated current by the PIN photodetector. The photo-generated current is converted into an electrical signal after passing through the transimpedance amplifier. The electrical signal is further amplified by the limiting amplifier, then outputs a fixed-amplitude electrical signal to the host. When the amplitude of the electrical signal received from the incident light conversion of the opposite optical transceiver module is lower than the set threshold, the module reports that the received signal is lost, the RX_LOS pin is high (logic "1"), which can be used to diagnose whether the physical signal is normal. The signal is operated in TTL level. The microprocessor inside the module monitors the module's operating voltage, temperature, transmitted optical power, received optical power, and laser bias current value in real time. The host acquires this information over a 2-wire serial bus.

Dimensions

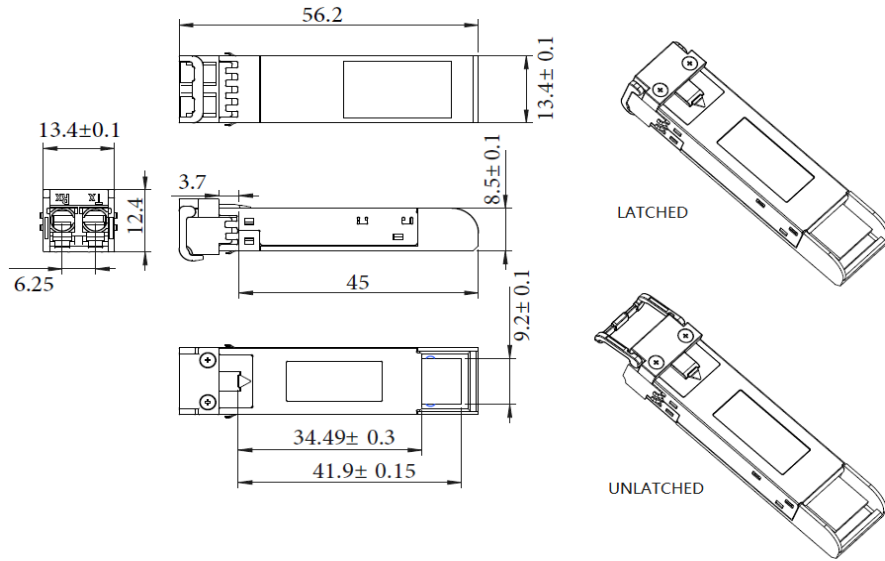

ALL DIMENSIONS ARE ±0.2mm UNLESS OTHERWISE SPECIFIED
UNIT: mm

Electrical Pad Layout

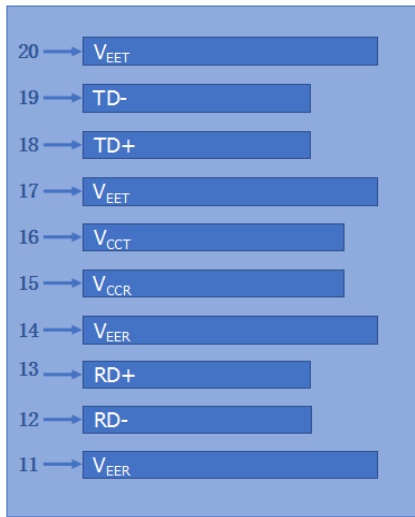

Top of Board

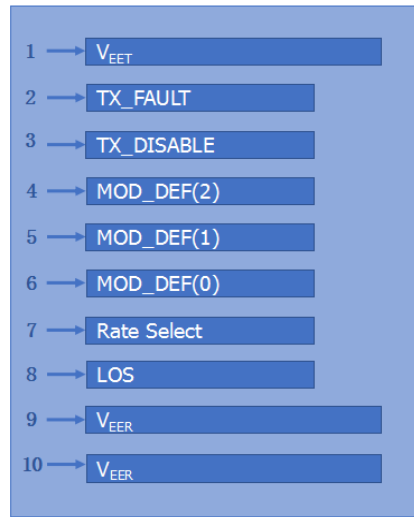

Bottom of Board

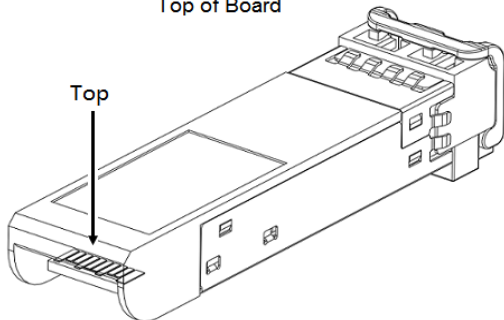

Top

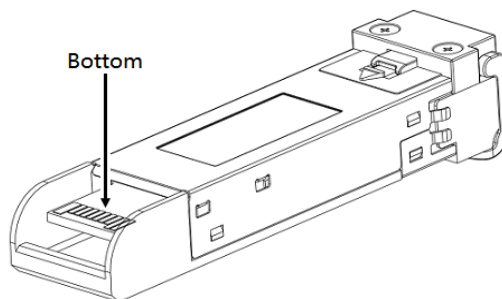

Bottom

Pin Assignment

PIN #	Symbol	Description	Remarks
1	V _{EET}	Transmitter ground (common with receiver ground)	1
2	TX_FAULT	Transmitter Fault. Not supported	
3	TX_DISABLE	Transmitter Disable. Laser output disabled on high or open	2
4	MOD_DEF(2)	Module Definition 2. Data line for serial ID	3
5	MOD_DEF(1)	Module Definition 1. Clock line for serial ID	3
6	MOD_DEF(0)	Module Definition 0. Grounded within the module	3
7	Rate Select	No connection required	
8	LOS	Loss of Signal indication. Logic 0 indicates normal operation	4
9	V _{EER}	Receiver ground (common with transmitter ground)	1
10	V _{EER}	Receiver ground (common with transmitter ground)	1
11	V _{EER}	Receiver ground (common with transmitter ground)	1
12	RD-	Receiver Inverted DATA out. AC coupled	
13	RD+	Receiver Non-inverted DATA out. AC coupled	
14	V _{EER}	Receiver ground (common with transmitter ground)	1
15	V _{CCR}	Receiver power supply	
16	V _{CCT}	Transmitter power supply	
17	V _{EET}	Transmitter ground (common with receiver ground)	1
18	TD+	Transmitter Non-Inverted DATA in. AC coupled	
19	TD-	Transmitter Inverted DATA in. AC coupled	
20	V _{EET}	Transmitter ground (common with receiver ground)	1

Notes:

1. Circuit ground is isolated from chassis ground
2. Disabled: T_{DIS} > 2V or open, Enabled: T_{DIS} < 0.8V
3. Should Be pulled up with 4.7k – 10k ohm on host board to a voltage between 2V and 3.6V
4. LOS is open collector output

References

1. IEEE standard 802.3. IEEE Standard Department, 2002.
2. [Small Form Factor Pluggable \(SFP\) Transceiver Multi-Source Agreement \(MSA\), INF-8074i.](#)
3. Fiber Channel Draft Physical Interface Specification (FC-PI 10.0).
4. [Digital Diagnostics Monitoring Interface for Optical Transceivers –SFF-8472.](#)